

ARCHITECTURAL

TITAN 472-RGBL is a 72x15 watts multi-chip RGBL, LED city wash. It has excellent-color mixing effect, high color saturation, high light efficiency, high illumination, high performance, and stability, it is realizable to achieve the perfect color interpretation and ultra-long light casting distance. Optional wireless DMX 512 control, it provides diverse lighting solutions for a variety of large outdoor lighting projects, an ideal lighting fixture for towers, bridges, large venues, integrated commercial building, and other large occasions.

SOURCE Light source: 72x15 watts multi-chip RGBL
LED life expectancy: 50,000 Hrs
Peak Intensity: 584300 cd (14°)

OPTICAL SYSTEM Optics: 14° , 25°
Light output: 5,000 Lux @ 10m @ 14°

CONTROL & PROGRAMMING Control Protocols: DMX 512
DMX control channels: 0-100%
Controllable sections: 8
Dimmer: 0% -100%; 16 Bit
Color Mixing: RGBL

ELECTRICAL Input Voltage: AC100 - 277V
Max Power: 1200 W
Power Factor: > 0.9

CONNECTIONS Power connection: 3m cable (input only)
Data connection: 3m cable (input + output)

PHYSICAL Dimensions: 881x252x569 mm
Net Weight: 46 kg
Color: Off - white (Gray, Black Optional)
Housing: Die-cast aluminum
Security: Anti-thunder shock protection design
IP Rating: 66
Operation temperature: - 40°C~45°C (operating) /
- 20°C~45°C (startup)

Dimensions

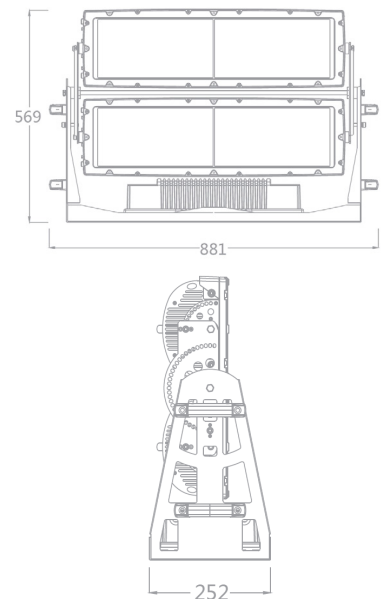

Luminous Diagram

