

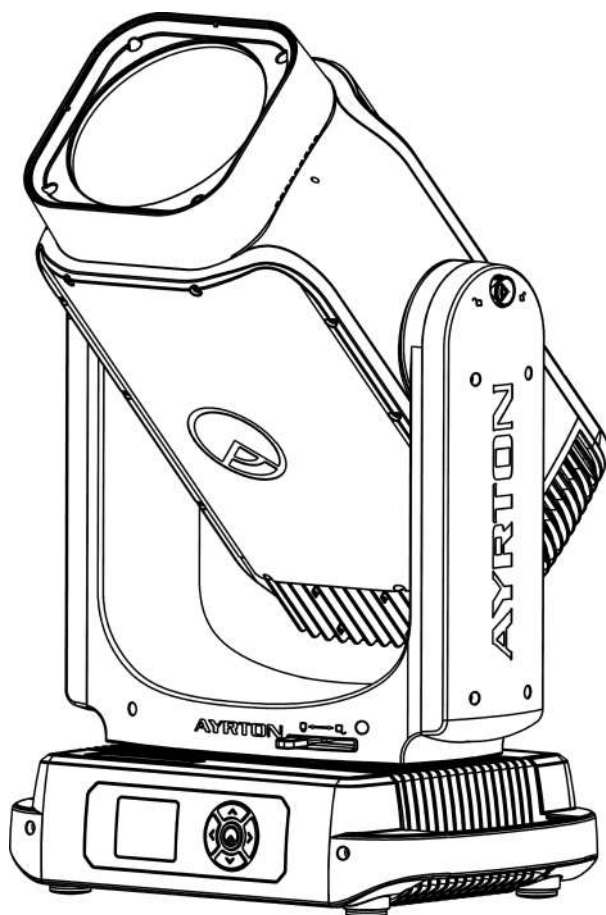

## User Manual



# COBRA

ULTRA BEAM

KEEP THIS MANUAL FOR FUTURE NEEDS 

## CONTENTS

<b>1. SAFETY INSTRUCTIONS</b>	<b>2</b>
<b>2. FEATURES</b>	<b>5</b>
<b>3. FIXTURE OVERVIEW</b>	<b>7</b>
<b>4. DIMENSIONAL DRAWINGS</b>	<b>8</b>
<b>5. INSTALLATION INSTRUCTIONS</b>	<b>12</b>
<b>6. DMX-512 CONTROL CONNECTION</b>	<b>15</b>
<b>7. DMX-512 CONNECTION WITH DMX TERMINATOR</b>	<b>15</b>
<b>8. DEVICE DMX START ADDRESS SELECTION</b>	<b>16</b>
<b>9. OPERATING INSTRUCTIONS OF THE INTERNAL DMX WIRELESS SYSTEM</b>	<b>16</b>
<b>10. DISPLAY</b>	<b>18</b>
<b>11. DMX PROTOCOL</b>	<b>39</b>
<b>12. ERROR MESSAGES</b>	<b>50</b>
<b>13. CLEANING AND MAINTENANCE</b>	<b>51</b>

# 1. SAFETY INSTRUCTIONS

## 1.1. IMPORTANT SAFETY WARNING

This device has left the factory in perfect condition. In order to maintain this condition and to ensure safe operation, it is absolutely necessary for the user to follow the safety instructions and warning notes written in this user manual.

In order to install, operate, and maintain the lighting fixture safely and correctly we suggest that the installation and operation be carried out by qualified technicians and these instructions be carefully followed.

The light source of this product is made of laser diodes. It complies with the related safety standard and classified as:

Class 1 Laser product (IEC 60825-1:2014)

RG3 (IEC 62471:2006)

Laser projectors shall not be delivered to any other party under an agreement of sale, lease, or loan unless and until the recipient demonstrates that they have a variance in effect at the time of delivery that permits them to produce laser light shows incorporating such projector(s).

No direct exposure to the beam shall be permitted.

Operators shall control access to the beam within the hazard distance or install the product at a height that will prevent eye exposure within the hazard distance.

	<b>RISK GROUP 3</b> WARNING: Possibly hazardous optical radiation emitted from this product. Do not look at operating lamp source. Eye injury may result.
---	---

	<b>CAUTION!</b> HIGH VOLTAGE. RISK OF SEVERE OR FATAL ELECTRIC SHOCK
---	---

	<b>CAUTION!</b> ALWAYS DISCONNECT MAINS SUPPLY BEFORE REMOVING ANY FIXTURE COVERS
---	--

	<b>CAUTION!</b> NEVER LOOK DIRECTLY INTO THE LIGHT SOURCE. SENSITIVE PERSONS MAY SUFFER AN EPILEPTIC SHOCK
---	---

	<b>CAUTION!</b> NEVER TOUCH THE DEVICE DURING OPERATION! COVERS MAY BE HOT
---	---

	<b>CAUTION!</b> THE LUMINAIRE SHOULD BE POSITIONED SO THAT PROLONGED STARING INTO THE LUMINAIRE AT A DISTANCE CLOSER THAN 58.3 M IS NOT EXPECTED
---	---

## CAUTION!

**Warning:** Changes or modifications to this unit not expressly approved by the party responsible for compliance could void the user's authority to operate the equipment.

**NOTE:** This equipment has been tested and found to comply with the limits for a Class



A digital device, pursuant to Part 15 of the FCC Rules. These limits are designed to provide reasonable protection against harmful interference when the equipment is operated in a commercial environment. This equipment generates, uses and can radiate radio frequency energy and, if not installed and used in accordance with the instruction manual, may cause harmful interference to radio communications. Operation of this equipment in a residential area is likely to cause harmful interference in which case the user will be required to correct the interference at his own expense.

### *Important:*



***Damage caused by the disregard of this user manual is not subject to warranty. The dealer and manufacturer will not accept liability for any resulting defects or problems.***

- If the device has been exposed to temperature changes due to environmental conditions, do not power on immediately. The resulting condensation could damage the device. Leave the device powered off until it has reached room temperature.
- Ensure the sealing rubber covers of powerCON and XLR connectors are fitted properly when the device is not in use, to avoid water ingress.
- This device falls under protection-class I. Therefore, it is essential that the device be earthed.
- If either lenses or display are damaged (damage may include cracks or gashes in the material) they must be replaced.
- Electrical connections, such as replacing the power plug, must be performed by a qualified person.
- Make sure that the available voltage is not higher than that which is stated in this manual.
- Make sure the power cord is never crushed or damaged by sharp edges. If this should be the case, replacement of the cable must be done by an authorized dealer.
- If the external flexible power cord of this device is damaged, it shall be exclusively replaced by the manufacturer or their service agent or a similar qualified person in order to avoid injury.
- When the device is not in use or before performing maintenance, always disconnect the device from the mains. Only handle the power cord from the plug. Never pull the plug out of a socket by tugging the power cord.
- When powered on for the first time, some smoke or smell may occur. This is caused by coating on metal parts when heated and is normal. If you are concerned, please contact your distributor.
- Do not focus the beam onto flammable surfaces. The minimum distance between the exiting lens of the device and the illuminated surface must be :
  - Min 25 m distance to the illuminated surface (narrowest zoom with full power)
  - Min 15 m distance to the illuminated surface (narrowest zoom with 78% intensity)
  - Min 8 m distance to the illuminated surface (narrowest zoom with 51% intensity)
- According to IEC62471-5, the distance from RG3 to RG1 is 45 meters.

**Please be aware that damage caused by any modifications to the device are not subject to warranty. Keep away from children and non-professionals.**

## 1.2. GENERAL GUIDELINES

- This device is a lighting effect for professional use on stages, in discotheques, theatres, etc.the device was designed for outdoor use.
- Scanning, projection, or reflection of laser and collateral radiation into audience or other accessible uncontrolled areas shall not be permitted except for diffuse reflections produced by the atmosphere, added atmospheric scattering media, and target screens.
- Laser radiation levels in excess of the limits of Class I shall not be permitted at any point less than 3.0 meters above any surface upon which persons other than operators, performers, or employees are permitted to stand or 2.5 meters below or in lateral separation from any place where such persons are permitted to be. Operators, performers, and employees shall not be required or allowed to view radiation above the limits of Class I or be exposed to radiation above Class IIIa.
- All laser light shows shall be under the direct and personal control of trained, competent operator(s). The operator(s) shall:
  - (1)、 Be an employee of the variance holder who will be responsible for the training and the conduct of the operator;
  - (2)、 Be located where all beam paths can be directly observed at all times;
  - (3)、 Immediately terminate the emission of light show radiation in the event of any unsafe condition; or for outdoor shows, upon request by any air traffic control officials.
- The projection system shall be securely mounted or immobilized to prevent unintended movement or misalignment. Beam masking will be provided as an inherent part of the system design to prevent overfilling of screens, beam stops, targets, etc.
- This fixture is only allowed to be operated within the maximum alternating current as stated in the technical specifications in section 2 of this manual.
- Handle the device with care, avoid shaking or using force when installing or maintaining the device.
- If you use the quick lock cam when rigging the device, make sure the quick lock fasteners are located in the quick lock holes correctly and securely.
- Operate the device only after having familiarized yourself with its functions.Do not permit operation by persons not qualified for operating the device.Most damage is the result of unprofessional operation.
- Please use the original packaging if the device is to be transported.
- The applicable temperature for the device is between -20°C to 45°C.Do not use the device outside of this temperature range.(Note: When the temperature detected by laser source between -20°C to 0°C, it need to wait some minutes for the heater to heat up the temperature to be above 0°C before lighting on.)

**For safety reasons, please be aware that all modifications to the device are forbidden. If this device is operated in any way different to the ones described in this manual, the product may suffer damage and the warranty becomes void.Furthermore, any other operation may lead to short-circuits, burns, electric shocks etc.**

## **2. FEATURES**

### **POWER SUPPLY**

- AC100-240V~, 50/60Hz
- Power Consumption: 480W

### **LIGHT SOURCE**

- Laser: 260W, White, Color Temperature 9000 ~ 10000K
- Extremely long Life: >12,000H

### **MOVEMENT**

- Pan movement: infinite rotation
- Tilt movement: infinite rotation
- Advanced moving system: fast, stable and quite, auto x-y repositioning

### **COLORS**

- CMY + CTO color mixing, uniform, linear and speed can be adjustable
- 1 Color wheel: 27 dichroic filters + open, indexable

### **GOBOS**

- Rotating gobo wheel: 12 interchangeable, rotating, and indexable, gobo+open
- “Slot in & out” gobo wheel system
- Fix gobo wheel: 79 + open, with different speed gobo shaking and gobo indexing

### **FEATURES**

- 3 Control channel modes: 35/33/45 channels
- 2 Operation modes: DMX-512, Master / Slave mode
- Strobe effect with 1-25 flashes per second and pulse effect
- 8 Rotating Prisms: 6-facet circular (2), 8-facet circular, 16-facet circular, 4-facet linear (2), 6-facet linear (2)
- Animation effect: can make special dynamic effect
- Focus: Motorized focus
- Frost: 2 frost filters
- Dimmer: 0%~100% full range dimming

### **DISPLAY**

- Advanced and convenient full –color LCD
- Pan and Tilt homing bypass: long press the center button to lock pan / tilt homing
- Can be changed 180° reverse to fit for different installation position

### **SOFTWARE**

Upgrades: fast and convenient through DMX cable with DMX-512 controller

Reset DMX address, reset can all be done by the DMX controller

Running time of fixture on display for reference

**OTHER SPEC**

Input signal isolation: guarantees stable signal transmission without interference  
Advanced RDM function

**WEIGHT**

Net weight: 33 kg

### 3. FIXTURE OVERVIEW

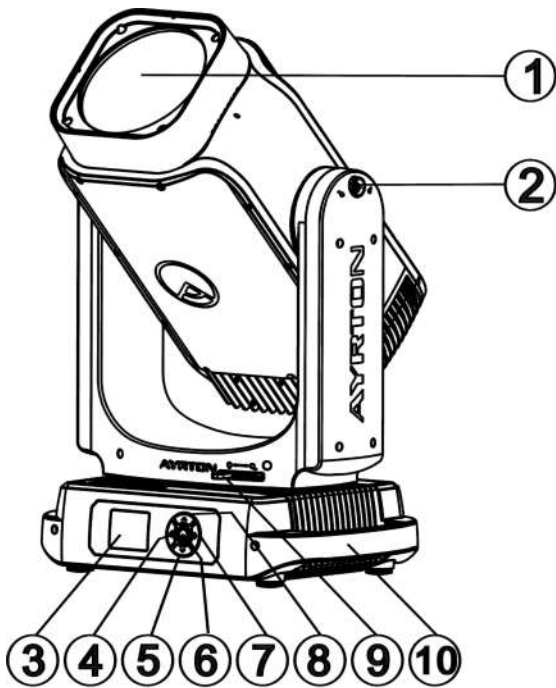

- 1) Front Lens
- 2) Tilt Lock
- 3) Display
- 4) Lef-button
- 5) Down-button
- 6) Center-button
- 7) Right-button
- 8) Up-button
- 9) Pan Lock
- 10) Handle

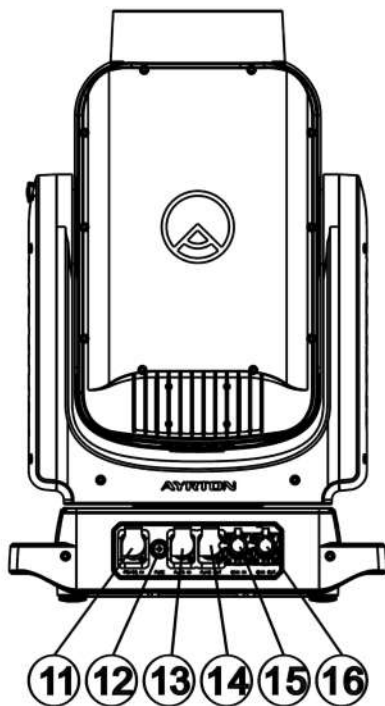

- 11) Power In
- 12) Fuse
- 13) RJ45 In
- 14) RJ45 Out
- 15) DMX In
- 16) DMX Out



## 4. DIMENSIONAL DRAWINGS

### 4.1. Fixture Dimension

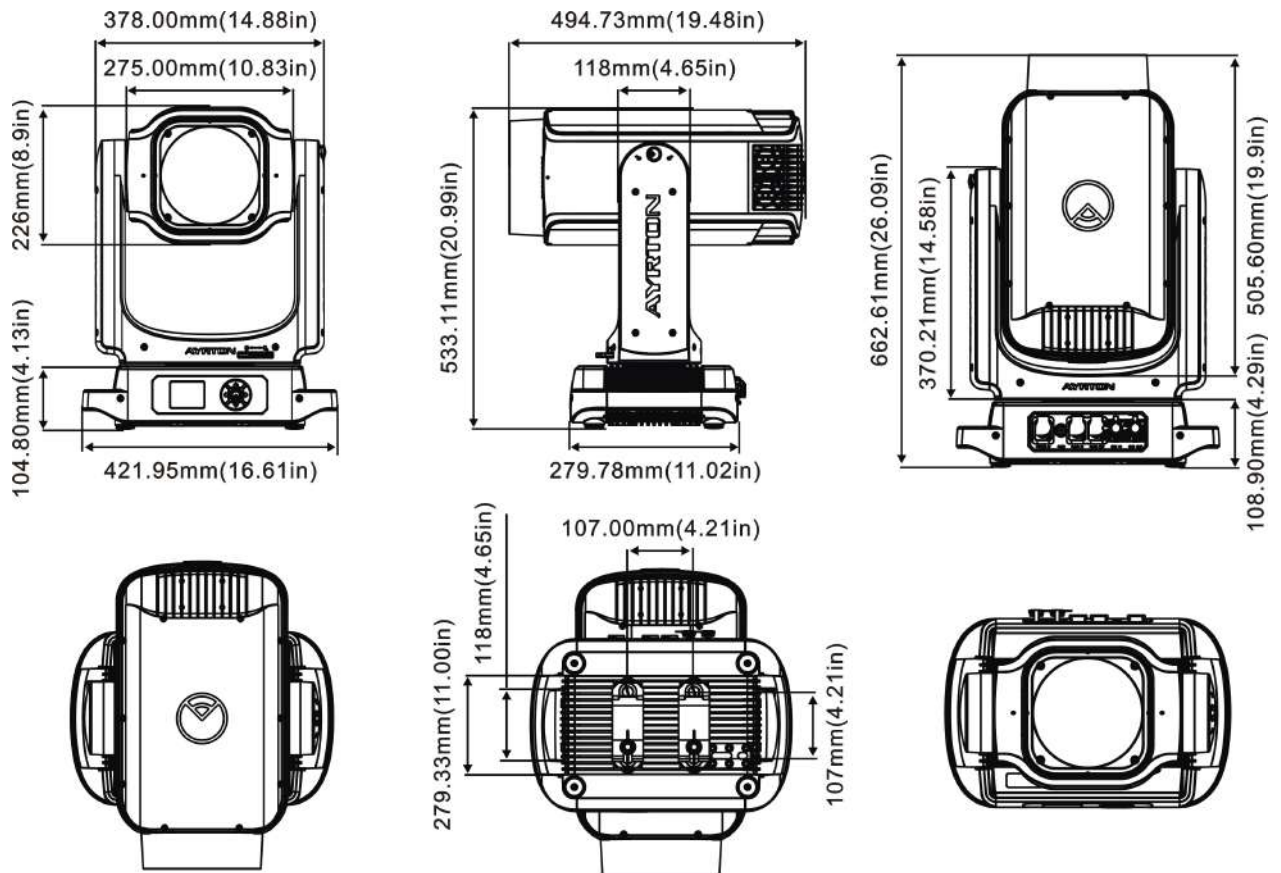

## 4.2. Color wheel

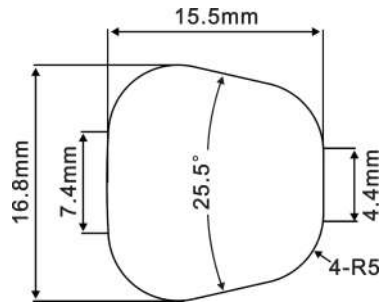

Outer Ring Color:

1. Green
2. Orange
3. Blue
4. Red
5. Pink
6. Medium Yellow
7. Deep purple
8. Velvet green
9. Amber
10. Light blue
11. Light red
12. Follies pink
13. Yellow
14. Slate blue
15. Dark Green
16. Dark amber
17. Medium Blue
18. Magical magenta
19. Oklahoma yellow

Inner Ring Color:

20. Congo blue
21. UV
22. Minus Green 1/4
23. Minus Green 1/2
24. CTB 1/4
25. CTB 1/2
26. CTB
27. Light Amber

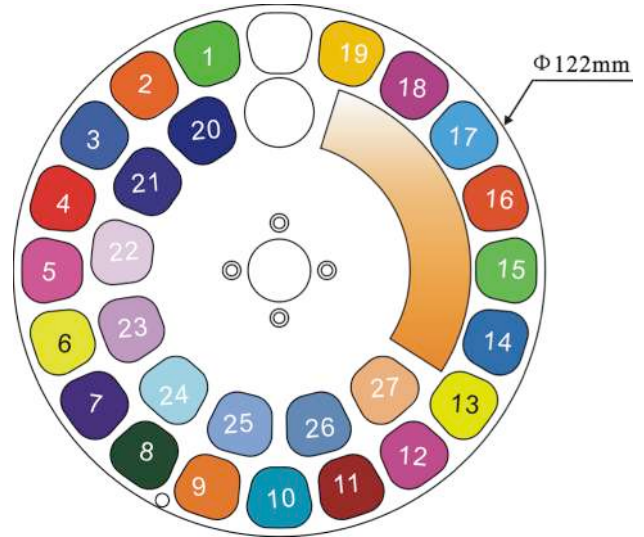

### 4.3. Gobo Filter Dimension

Rotating Gobo:

Metal Gobo:

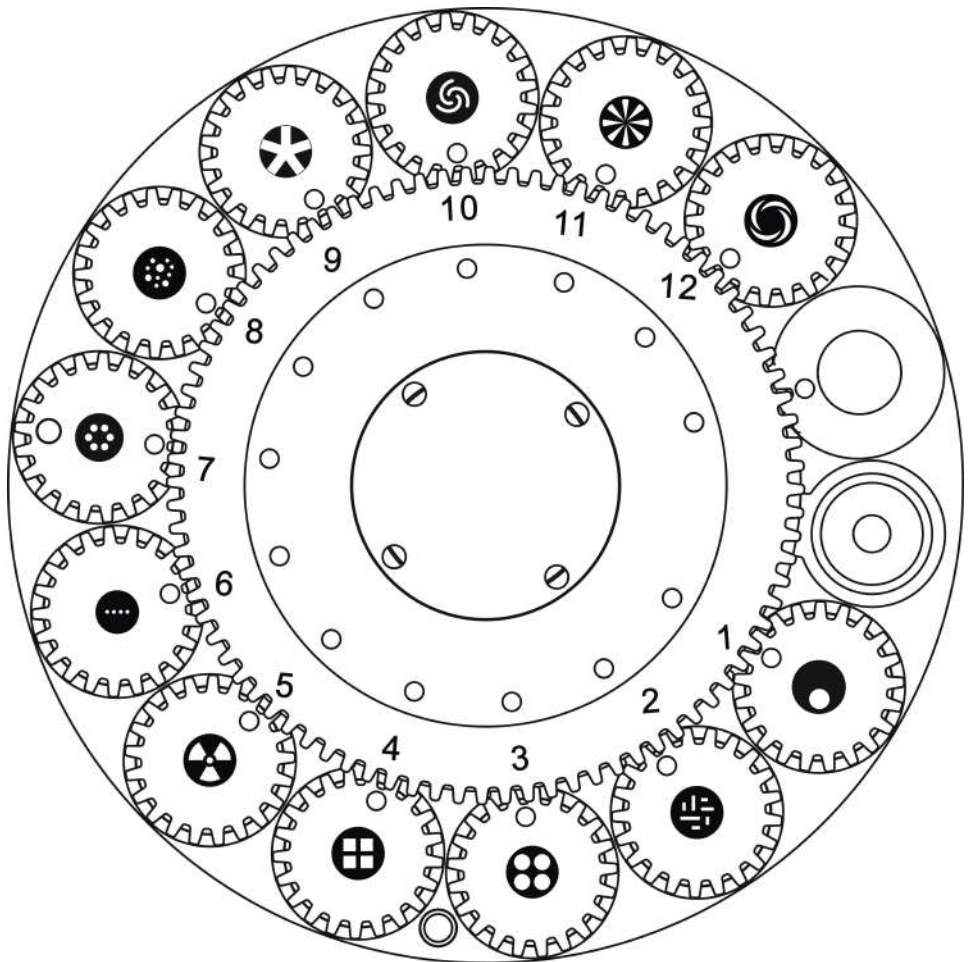
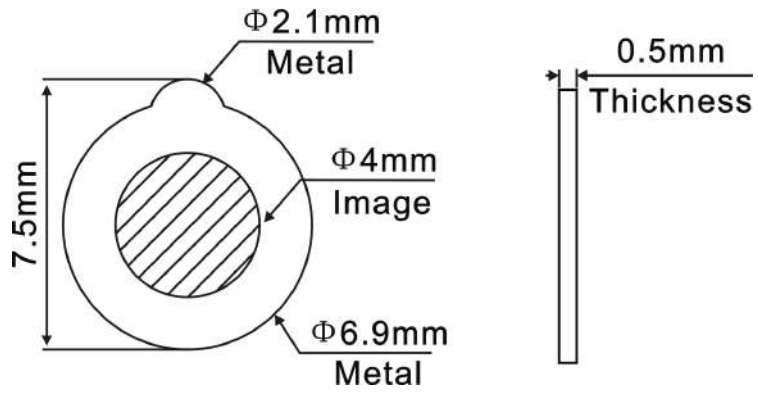

4.4. Fix Gobo Wheel Dimension

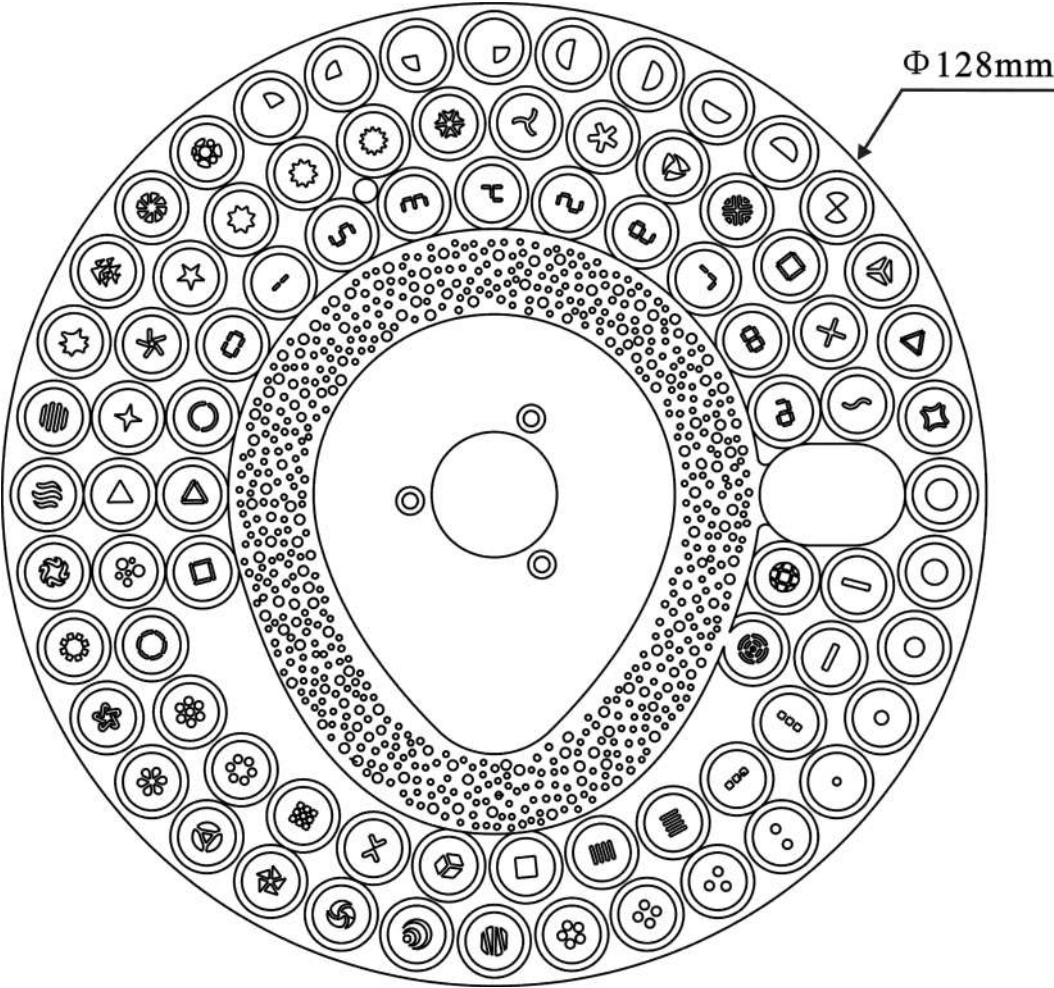

## 5. INSTALLATION INSTRUCTIONS

### 5.1. Rigging the device



#### **CAUTION!**

PLEASE CONSIDER THE RESPECTIVE NATIONAL NORMS DURING THE INSTALLATION. THE INSTALLATION MUST ONLY BE CARRIED OUT BY A QUALIFIED PERSON.

- The applicable temperature for the lighting is between -20°C to 45°C. Do not use the lighting under or above the temperature.
- The installation of the effect has to be built and constructed in a way that it can hold 10 times the weight for 1 hour without any harming deformation.
- The installation must always be secured with a secondary safety attachment, e.g. an appropriate safety rope.
- Never stand directly below the device when mounting, removing or servicing the fixture.
- The operator has to make sure the safety relating and machine technical installations are approved by an expert before taking the device into operation for the first time.
- These installations have to be approved by a skilled person once a year.
- Overhead mounting requires extensive experience, including amongst others calculating working load limits, installation material being used, and periodic safety inspection of all installation material and the device. If you lack these qualifications, do not attempt the installation yourself. Improper installation can result in bodily injury.

## 5.2. Rigging using the omega brackets

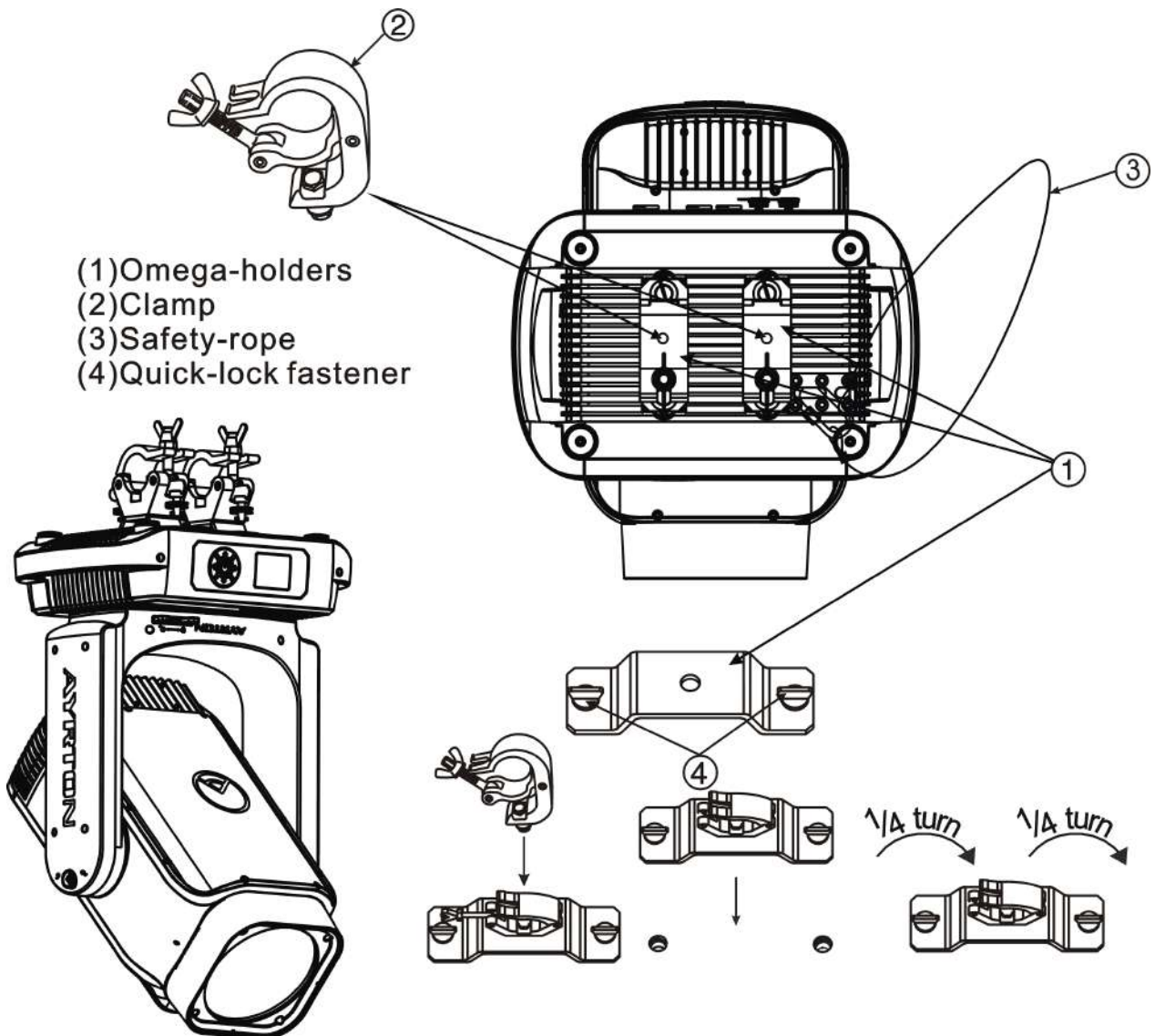

- Fix the clamp to the bracket by tightening the M12 nut and bolt to the bracket through the  $\Phi 13$  hole in the middle of the bracket.
- Insert the quick-lock fasteners of the first Omega holder into the respective holes on the bottom of the device. Tighten the quick-lock fasteners fully clockwise.
- Install the second Omega holder.
- Pull the safety cable through the holes on the bottom of the base and over the trussing system or another suitable rigging point. Insert the end into the carabiner and tighten the safety screw.



### Important:

This step is very important to ensure safe rigging of the fixture.



### 5.3. RIGGING DRAWINGS

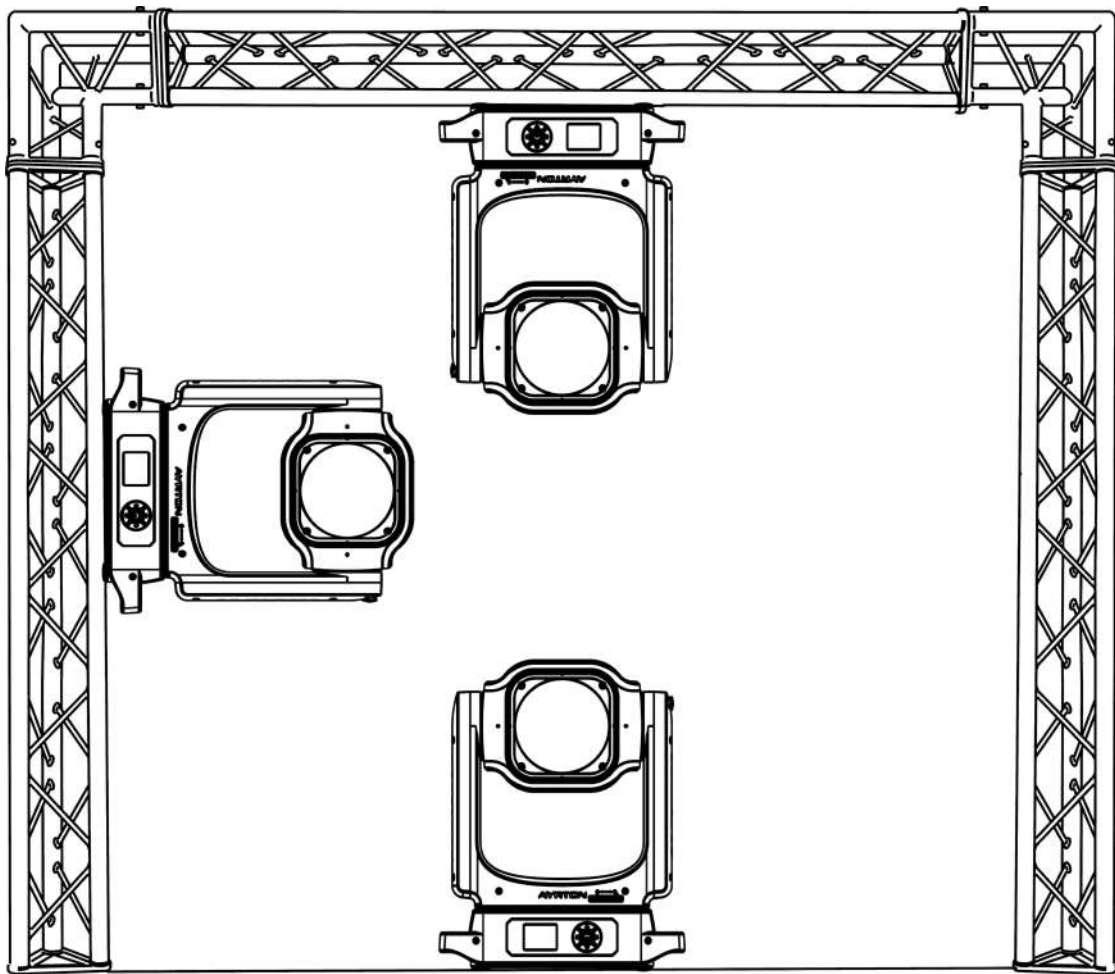

- Be sure this fixture is kept at least 0.1m away from any flammable materials (decoration etc.).
- Always use and install the supplied safety cable as a safety measure to prevent accidental damage and/or injury in the event the clamp fails.
- Rig the projector high enough to provide clearance for people who may walk beneath the beam path or establishing a restricted access area that extends beyond the beam hazard distance.
- While fixed installation at locations other than cinema theaters should be installed at a height not lower than 3 m vertically. The lowest tip of the Hazard Zone should be no lower than 3 m measured vertically above the floor. Horizontal clearance to the Hazard Zone should be 2.5 m measured horizontally. Any human access to the Hazard Zone, if applicable, is to be restricted by barriers. The fixed installation should be performed by authorized installers, who are trained to perform installations in accordance with the manufacturer's instructions.



**Important:**

**Overhead rigging requires extensive experience, including (but not limited to) calculating working load limits, specifying installation/ rigging materials, and periodic safety inspection of all installation material as well as the device. If you lack these qualifications, do not attempt the rigging of this device yourself. Improper installation/ rigging can result in serious bodily injury.**

## 6. DMX-512 CONTROL CONNECTION

Connect the provided male side of the XLR cable to the female XLR output of your controller and the female side of the XLR cable to the male XLR input of the device. You can connect multiple devices together in a serial fashion. The cable needed should be two core, screened cable with XLR input and output connectors. Please refer to the diagram below.

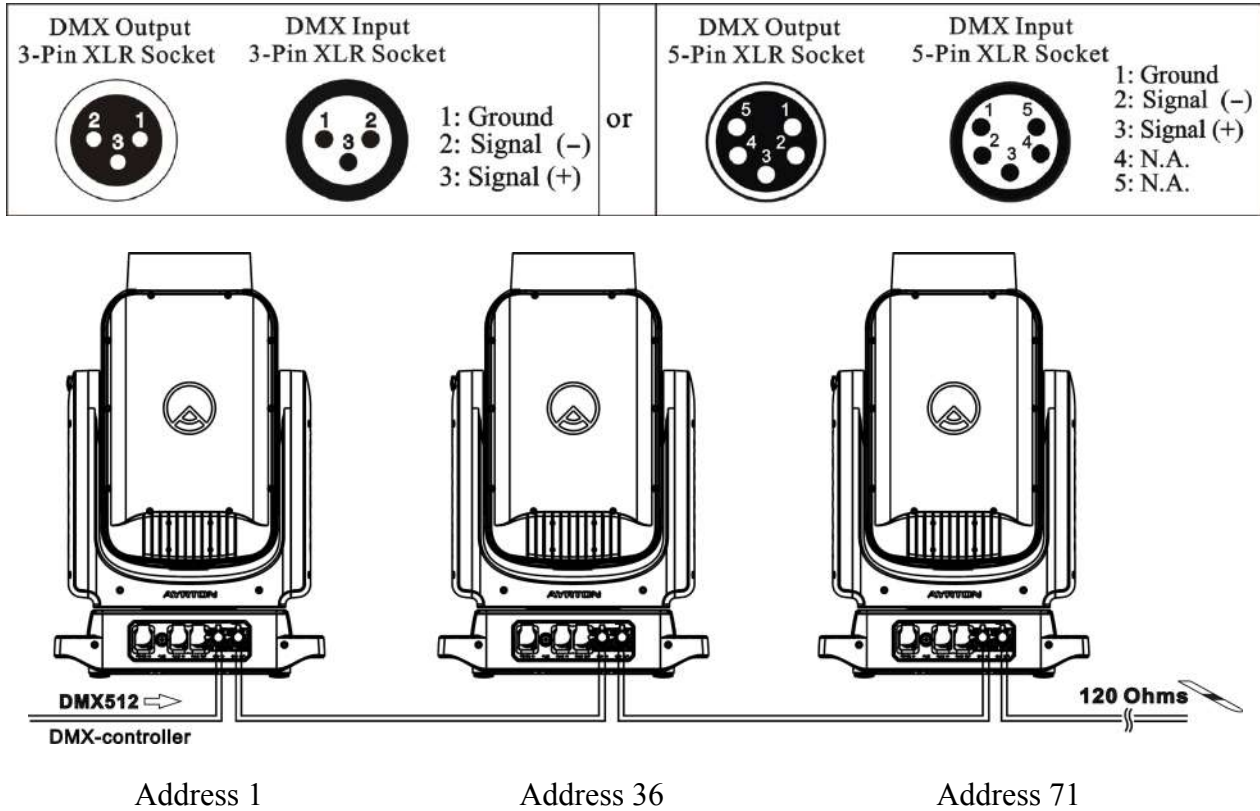

## 7. DMX-512 CONNECTION WITH DMX TERMINATOR

For installations where the DMX cable has to run over a long distance or is in an electrically noisy environment, such as in a discotheque, it is recommended to use a DMX terminator. This helps in preventing corruption of the digital control signal caused by electrical noise. The DMX terminator is an XLR plug with a 120 Ω resistor connected between pins 2 and 3, which is then plugged into the output (female) XLR socket of the last fixture in the chain. Please see illustrations below.

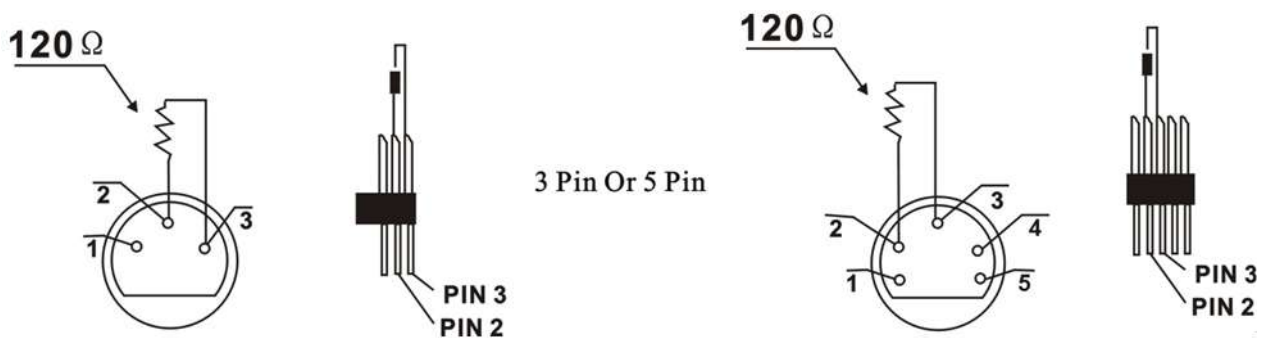



## 8. DEVICE DMX START ADDRESS SELECTION

All fixtures should be given a DMX starting address when using a DMX signal, so that the correct fixture responds to the correct control signals. This digital starting address is the channel number from which the fixture starts to “listen” to the digital control information sent out from the DMX controller. The allocation of this starting address is achieved by setting the correct address number on the display located on the base of the device.

You can set the same starting address for all fixtures or a group of fixtures, or set different addresses for each fixture individually.

If you set the same address on all devices, all the devices will start to “listen” to the same control signal from the same channel number. In other words, changing the settings of one channel will affect all the fixtures simultaneously.

If you set a different address, each unit will start to “listen” to the channel number you have set, based on the quantity of control channels of the unit. That means changing the settings of one channel will affect only the selected device.

In the case of the LED moving head, in 35 channel mode, you should set the starting address of the first unit to 1, the second unit to 36(35 + 1), the third unit to 71 (35 + 36), and so on.

## 9. OPERATING INSTRUCTIONS OF THE INTERNAL DMX WIRELESS SYSTEM

### 9.1 Equipments:

DMX 512 controller, wireless transmitter, and the fixtures with wireless receiver.

### 9.2 Message from the LED indicator:

- 1) Rapid flashing red/Green: logging in to a transmitter.
- 2) Slow flashing Red/Green: Logged on a transmitter and the DMX line is idle (No DMX is connected to transmitter).
- 3) Solid Green: Logged on to a transmitter and receiving DMX data.
- 4) Solid Red: Not logged on to a transmitter (free).

### 9.3 WDMX in the menu of the fixture:

On a fixture installed with wireless system, in order to switch between wireless control system and traditional DMX control (with cable), a new menu WDMX is added to the display board.

ON: (Activate WDMX)

- 1) When the fixture is on power, and the WDMX is activated to ON status, but did not connect to the controller and did not log in to the transmitter, the fixture will search for the DMX signal source. If the fixture is connected to the DMX controller it can be controlled by DMX controller; if it is log in to the wireless transmitter, it can be controlled by the Transmitter.
- 2) When the fixture is power off, and the WDMX is in ON status, if the fixture is connected to DMX controller. After the fixture is power on, it can be controlled only by the DMX controller which connected. The fixture can log in the wireless transmitter, and receive only radio signal from transmitter, but not DMX from the transmitter.

OFF: (De-activate WDMX)

In this status, wireless system is not activated, so the fixture can not log in the transmitter.

REST: (reset WDMX memory)

Can remove the fixture from the connection with the transmitter, the fixture become free and ready to log in any transmitter.

#### **9.4 Setup the wireless system:**

- 1) Connect the transmitter with the DMX controller.
- 2) To make the fixture installed with wireless receiver log in to the transmitter.
  - a) Initially, the indicator on the receiver fixture should be in Solid red.
  - b) Press and hold the configuration button on transmitter for less than 3 seconds the red/green LEDs on the transmitter and the receiver fixture will flash rapidly for about 5~ 10 seconds while the system goes through its setup procedure.
  - c) Once the receiver fixture is logged in to the transmitter (T1), the fixture with wireless receiver will keep the memory, even if restart the power, this unit will log in the transmitter (T1) automatically.
- 3) Use the DMX 512 to control the fixture

#### **9.5 Remove the receivers from transmitter (T1) and to log in to another transmitter (T2) :**

Case 1: Remove a receiver:

- a) On the control board of the fixture, enter menu to activated the function of REST;
- b) The LED for wireless on the fixture should turn to Solid red; the receiver can log out from the transmitter (T1);
- c) press the configuration button on transmitter (T2) for less than 3 second, then the fixture will start to connect with the transmitter (T2).

Case 2: Remove all receivers from a transmitter (T1) to log in to T2:





- a) Press and hold the configuration button on the T1 as least 5 seconds, can clear the connection with all the fixtures;
- b) All the red/green LEDs on the receiver fixtures will turn to Solid red to indicate that the receivers are unassigned and removed from the transmitter (T1);
- c) Press and hold the configuration button on the T2 less then less than 3 second, the fixtures will connect with the T2.



#### **PS:**

1. Please log the receivers out from the transmitter after every job, so that the receivers are in free un assigned state and ready to be assigned to a transmitter.
2. Do not connect the fixture which is under the communication of wireless system to the DMX controller, otherwise it will cause interference from the DMX controller.

## 10. DISPLAY

The Display offers buttons features: you can set the starting address, run the pre-programmed program or reset the device.

The main menu is accessed by double clicking  -button until the display starts flashing. Browse through the menu by pressing the  -button,  -button,  -button or  - button.

Press  for 2 seconds in order to exit menu, double click  for confirm. After accessing the edit mode, the unit will automatically exit to the main menu after 15 seconds from the last button press.

When the unit is powered on, if no data signal is connected after 1 minute, then the display will switch off automatically.

### Default settings shaded

Address	Address	DMX address:001-XXX :	DMX address setting	
Mode	User Mode	Stand Mode Basic Mode <b>Extend Mode</b> User Mode A User Mode B User Mode C	User's mode to change channel numbers	
	Edit User ModeA :	Max channel PAN :	Preset User modes A,B,C :	
Options	Status	No DMX Mode Sun protection Pan Reverse Tilt Reverse Pan Degree Tilt Degree Feedback Init PAN Init TILT Prerig INIT Reset Mode Pan/Tilt Spd CMY Spd CTO Control Zoom/Focus Spd Hibernation DMX Output	Close/ <b>Hold</b> /Auto <b>ON</b> /OFF <b>ON</b> / <b>OFF</b> <b>ON</b> / <b>OFF</b> 630/ <b>540</b> <b>270</b> /540 <b>ON</b> /OFF <b>ON</b> /OFF <b>ON</b> / <b>OFF</b> <b>Fast</b> /All Rot Gobos <b>Medium</b> /Fast/Slow Slow/Fast <b>Color Wheel</b> /Separate Ch Fast/Medium/Slow <b>OFF</b> , 01M~99M <b>ON</b> / <b>OFF</b>	Hold if no DMX Sun protection movement Pan Reverse movement Tilt Reverse movement Pan Degree Select Tilt Degree Movement Feedback Init PAN Init TILT Prerig INIT Reset Mode Movement Speed CMY Spd CTO Control Zoom/Focus Spd Stand by Mode Ethernet to DMX

Service PIN	Service PIN Set Ip Set Mask Ip DHCP Cross Load SW Clr Laser Timer Clr Error Info	Password=XXX xxx.xxx.xxx.xxx xxx.xxx.xxx.xxx ON/OFF ON/OFF ON/OFF ON/OFF	Service Password”=050” Set Ip Set Mask Ip DHCP Cross Load SW Clr Laser Timer Clr Error Info
Fans Control	Fans Speed	Auto Stage Silence Super Silence	Fans Speed select
	Constant Fans	ON/OFF	Constant Fans
Disp.Setting	Shutoff Time Flip Display Key Lock DispFlash	02~60m05m ON/OFF ON/OFF ON/OFF	Display shutoff time Reverse 180 degree Key Lock DispFlash
Signal Select	DMX WDMX Art-Net sACN		DMX WDMX Art-Net sACN
Temp. C/F	Celsius Fahrenheit		Temperature switch between <input type="checkbox"/> / <input type="checkbox"/>
Initial Pos.	PAN =XXX		Initial effect position
Wireless DMX	Activate WDMX Rest WDMX		Activate WDMX Rest WDMX
Dim Curve	Square Law Linear		Dim Curve
Refresh Select	1.2K 2.4K 16K 25K		Refresh Select
Prism Mode	Simple/Full		Prism Mode
Reset P/T Fade	ON/OFF		Reset P/T Fade
Illumination Limit	25m Distance /15m Distance/8m Distance		Illumination Limit
Trigger	DMX Value Disp. Set To Slave Auto Program	PAN..... Slave1,Slave2,Slave3 Master / Alone	DMX Value Disp. Set To Slave Auto Program
ResetDefault	ON/OFF		Restore factory set.
Reset User set	Address	DMX address:001-XXX :	DMX address setting
	Mode	Stand Mode Basic Mode Extend Mode User Mode A User Mode B User Mode C	User’s mode to change channel numbers

		Fans Speed	Auto Stage Silence Super Silence	Fans Speed select
		Constant Fans	ON/OFF	Constant Fans
Info	Time Info.	Current Time Ttl Life Hrs Last Run Hrs Laser Hours Timer PIN Clr Last Run		XXXX(Hours) XXXX(Hours) XXXX(Hours) XXXX(Hours) Password=XXX ON/OFF
	Temp. Info	Head Temp.		XXX□/□
	Humidity	x%		Humidity Information
	Fan Info.	xxxxRPM		Fan Information
	Software Ver	V1.0.....		Software version
	Network	IP,Mask,Mac		Network
	Error Info.	Error Record 1 :		Error Info.
Test	Home	All Pan&Tilt Color Gobo Other		Reset All Reset Pan&Tilt Reset Color Reset Gobo Reset Other
	Test Channel	PAN .....		Test function
	Manual Ctrl.	PAN =XXX :		Fine adjustment of the lamp
	Calibration	-Password- PAN :		Password "050" Calbrate and adjust the effects to standard/right position
	Gobo Replace	Gobo Wheel 1		Gobo Replace
Preset	Select Prog.	Prog. Part 1 = Program 1 ~ 10 Prog. Part 2 = Program 1 ~ 10 Prog. Part 3 = Program 1 ~ 10	Program 1 Program 2 Program 3	Select programs to be run
	Edit Prog.	Program 1 : Program 10	Program Test Step 01=SCxxx Step 64=SCxxx	Testing program Program in loop Save and exit
	Edit Scenes	Edit Scene 001 ~ Edit Scene 250	Pan,Tilt,..... --Fade Time-- --Secne Time-- Input By Outside	Save and automatically return manual scenes edit
	Scenes Input	XX~XX		Scenes Input

## **10.1.Address**

### **10.1.1. Set DMX Address**

With this function, you can adjust the desired DMX-address via the Display.

1. Double clicking center button to access main menu.
2. Tap the <Up/Down> button until “Address” is displayed.
3. Double clicking center button, the display will show “Set DMX Address” .
4. Tap the <Up/Down> button, the display will show “001~XXX” .
5. Double click the center button to confirm or long press the center button to return to the main menu.

## **10.2.Mode**

### **10.2.1. User Mode**

With this function, you can create user defined channel orders.

1. Double clicking center button to access main menu; Tap the <Up/Down> button until “Mode” is displayed. Double clicking center button to enter.
2. Press <Up/Down>, the display will show “User Mode” .
3. Double clicking center button to enter.
4. When in “Extend Mode”, Press <Up/Down> button to select “Basic Mode”, “Stand Mode”, “User Mode A”, “User Mode B” and “User Mode C” .
5. Double click the center button to confirm or long press the center button to return to the main menu.

### **10.2.2. Edit User Mode**

With this function, you can adjust the rest user defined channel order.

1. Double clicking center button to access main menu; Tap the <Up/Down> button until “Mode” is displayed. Double clicking center button to enter.
2. Press <Up/Down>, the display will show “Edit User Mode” .
3. Double clicking center button to enter.
4. Set up “Max Channel=xxx” and select channel value.
5. Set up “Mode B” and “Mode C” by the same way.
6. Double click the center button to confirm or long press the center button to return to the main menu.

## **10.3.Options**

### **10.3.1. Status Settings**

#### **No DMX Status**

With this function, when no DMX signal is detected, the unit will keep the last DMX status or close the shutter or run an automatic sequence. The default is hold.

1. Double clicking center button to access main menu.
2. Tap the <Up/Down> button until “Options” is displayed.
3. Double clicking center button to access “Options”, Tap the <Up/Down> button to select “Status” .
4. Double clicking center button to access “Status” menu, Tap the <Up/Down> button to select “No DMX Status” .
5. Double clicking center button to access “No DMX Status”, The display will show “Hold”, Tap the <Up/Down> button to select “Close”, “Auto” .

6. Double click the center button to confirm or long press the center button to return to the main menu.

### **Sun Protection**

With this function you can activate the Sun Protection-movement. Unit will automatically tilt down the head when no signal is detected.

1. Double clicking center button to access main menu.
2. Tap the <Up/Down> button until “Options” is displayed.
3. Double clicking center button to access “Options”, Tap the <Up/Down> button to select “Status” .
4. Double clicking center button to access “Status” menu, Tap the <Up/Down> button to select “Sun Protection” .
5. Double clicking center button to access “Sun Protection”, The display will show “ON”, Turn the rotary knob to select “OFF” .
6. Double click the center button to confirm or long press the center button to return to the main menu.

### **Pan Reverse**

With this function you can reverse the Pan-movement.

1. Double clicking center button to access main menu.
2. Tap the <Up/Down> button until “Options” is displayed.
3. Double clicking center button to access “Options”, Tap the <Up/Down> button to select “Status” .
4. Double clicking center button to access “Status” menu, Tap the <Up/Down> button to select “Pan Reverse” .
5. Double clicking center button to access “Pan Reverse”, The display will show “OFF”, Tap the <Up/Down> button to select “NO” .
6. Double click the center button to confirm or long press the center button to return to the main menu.

### **Tilt Reverse**

With this function you can reverse the Tilt-movement.

1. Double clicking center button to access main menu.
2. Tap the <Up/Down> button until “Options” is displayed.
3. Double clicking center button to access “Options”, Tap the <Up/Down> button to select “Status” .
4. Double clicking center button to access “Status” menu, Tap the <Up/Down> button to select “Tilt Reverse” .
5. Double clicking center button to access “Tilt Reverse”, The display will show “OFF”, Tap the <Up/Down> button to select “NO” .
6. Double click the center button to confirm or long press the center button to return to the main menu.

### **Pan Degree**

With this function, you can select pan degree for 630° or 540°.

1. Double clicking center button to access main menu.
2. Tap the <Up/Down> button until “Options” is displayed.
3. Double clicking center button to access “Options”, Tap the <Up/Down> button to select

“Status” .

4. Double clicking center button to access “Status” menu, Tap the <Up/Down> button to select “Pan Degree” .
5. Double clicking center button to access “Pan Degree”, The display will show “540”, Tap the <Up/Down> button to select “630” .
6. Double click the center button to confirm or long press the center button to return to the main menu.

### **Tilt Degree**

With this function, you can select tilt degree for 270° or 540°.

1. Double clicking center button to access main menu.
2. Tap the <Up/Down> button until “Options” is displayed.
3. Double clicking center button to access “Options”, Tap the <Up/Down> button to select “Status” .
4. Double clicking center button to access “Status” menu, Tap the <Up/Down> button to select “Tilt Degree” .
5. Double clicking center button to access “Tilt Degree”, The display will show “270”, Tap the <Up/Down> button to select “540” .
6. Double click the center button to confirm or long press the center button to return to the main menu.

### **Feedback**

With this function, you can feedback switch of pan movement or tilt movement.

1. Double clicking center button to access main menu.
2. Tap the <Up/Down> button until “Options” is displayed.
3. Double clicking center button to access “Options”, Tap the <Up/Down> button to select “Status” .
4. Double clicking center button to access “Status” menu, Tap the <Up/Down> button to select “Feedback” .
5. Double clicking center button to access “Feedback”, The display will show “ON”, Tap the <Up/Down> button to select “OFF” .
6. Double click the center button to confirm or long press the center button to return to the main menu.

### **Init PAN**

This function allows you to deactivate the Pan movement during init process.

1. Double clicking center button to access main menu.
2. Tap the <Up/Down> button until “Options” is displayed.
3. Double clicking center button to access “Options”, Tap the <Up/Down> button to select “Status” .
4. Double clicking center button to access “Status” menu, Tap the <Up/Down> button to select “Init PAN” .
5. Double clicking center button to access “Init PAN”, The display will show “ON”, Tap the <Up/Down> button to select “OFF” .
6. Double click the center button to confirm or long press the center button to return to the main menu.

### **Init TILT**



This function allows you to deactivate the Tilt movement during init process.

1. Double clicking center button to access main menu.
2. Tap the <Up/Down> button until “Options” is displayed.
3. Double clicking center button to access “Options”, Tap the <Up/Down> button to select “Status” .
4. Double clicking center button to access “Status” menu, Tap the <Up/Down> button to select “Init TILT” .
5. Double clicking center button to access “Init TILT”, The display will show “ON”, Tap the <Up/Down> button to select “OFF” .
6. Double click the center button to confirm or long press the center button to return to the main menu.

### **Prerig INIT**

1. Double clicking center button to access main menu.
2. Tap the <Up/Down> button until “Options” is displayed.
3. Double clicking center button to access “Options”, Tap the <Up/Down> button to select “Status” .
4. Double clicking center button to access “Status” menu, Tap the <Up/Down> button to select “Prerig INIT” .
5. Double clicking center button to access “Prerig INIT”, The display will show “OFF”, Tap the <Up/Down> button to select “ON” .
6. Double click the center button to confirm or long press the center button to return to the main menu.

### **Reset Mode**

1. Double clicking center button to access main menu.
2. Tap the <Up/Down> button until “Options” is displayed.
3. Double clicking center button to access “Options”, Tap the <Up/Down> button to select “Status” .
4. Double clicking center button to access “Status” menu, Tap the <Up/Down> button to select “Reset Mode” .
5. Double clicking center button to access “Reset Mode”, The display will show “Fast”, Tap the <Up/Down> button to select “All Rot Gobos” .
6. Double click the center button to confirm or long press the center button to return to the main menu.

### **Pan/Tilt Spd**

With this function, you can select scan mode from Medium、Fast and Slow.

1. Double clicking center button to access main menu.
2. Tap the <Up/Down> button until “Options” is displayed.
3. Double clicking center button to access “Options”, Tap the <Up/Down> button to select “Status” .
4. Double clicking center button to access “Status” menu, Tap the <Up/Down> button to select “Pan/Tilt Spd” .
5. Double clicking center button to access “Pan/Tilt Spd”, The display will show “Medium”, Tap the <Up/Down> button to select “Medium”, “Fast”, “Slow” .
6. Double click the center button to confirm or long press the center button to return to the main menu.

### **CMY Spd**

With this function, you can select CMY mode from Slow and Fast.

1. Double clicking center button to access main menu.
2. Tap the <Up/Down> button until “Options” is displayed.
3. Double clicking center button to access “Options”, Tap the <Up/Down> button to select “Status” .
4. Double clicking center button to access “Status” menu, Tap the <Up/Down> button to select “CMY Spd” .
5. Double clicking center button to access “CMY Spd”, The display will show “Slow”, Turn the rotary knob to select “Slow”, “Fast” .
6. Double click the center button to confirm or long press the center button to return to the main menu.

### **CTO Control**

1. Double clicking center button to access main menu.
2. Tap the <Up/Down> button until “Options” is displayed.
3. Double clicking center button to access “Options”, Tap the <Up/Down> button to select “Status” .
4. Double clicking center button to access “Status” menu, Tap the <Up/Down> button to select “CTO Control” .
5. Double clicking center button to access “CTO Control”, The display will show “Color Wheel”, Turn the rotary knob to select “Separate Ch” .
6. Double click the center button to confirm or long press the center button to return to the main menu.

### **Zoom/Focus Spd**

With this function, you can select zoom/focus mode from Fast, Medium and Slow.

1. Double clicking center button to access main menu.
2. Tap the <Up/Down> button until “Options” is displayed.
3. Double clicking center button to access “Options”, Tap the <Up/Down> button to select “Status” .
4. Double clicking center button to access “Status” menu, Tap the <Up/Down> button to select “Zoom/Focus Spd” .
5. Double clicking center button to access “Zoom/Focus Spd”, The display will show “Fast”, Tap the <Up/Down> button to select “Fast”, “Medium”, “Slow” .
6. Double click the center button to confirm or long press the center button to return to the main menu.

### **Hibernation: Standby mode**

The device and step motors will be power off if the fixture stay without DMX signal for 15 mins (Factory default). And the fixture will be reset before working once it receive DMX signal again.

1. Double clicking center button to access main menu.
2. Tap the <Up/Down> button until “Options” is displayed.
3. Double clicking center button to access “Options”, Tap the <Up/Down> button to select “Status” .
4. Double clicking center button to access “Status” menu, Tap the <Up/Down> button to

- select “Hibernation” .
5. Double clicking center button to access “Hibernation”, The display will show “OFF”, Tap the <Up/Down> button to select “01M”, “02M” . . . “99M” .
  6. Double click the center button to confirm or long press the center button to return to the main menu.

### **DMX Output**

With this function, you can select Art-Net to DMX.

1. Double clicking center button to access main menu.
2. Tap the <Up/Down> button until “Options” is displayed.
3. Double clicking center button to access “Options”, Tap the <Up/Down> button to select “Status” .
4. Double clicking center button to access “Status” menu, Tap the <Up/Down> button to select “DMX Output” .
5. Double clicking center button to access “DMX Output”, The display will show “OFF”, Tap the <Up/Down> button to select “ON” .
6. Double click the center button to confirm or long press the center button to return to the main menu.

### **10.3.2. Service PIN**

#### **Password**

The Password for this function is “050” .

#### **Set IP**

1. Double clicking center button to access main menu.
2. Tap the <Up/Down> button until “Options” is displayed.
3. Double clicking center button to access “Options”, Tap the <Up/Down> button to select “Service PIN” .
4. Double clicking center button to access “Service PIN” menu, Tap the <Up/Down> button to select “Set IP” .
5. Double clicking center button to access “Set IP”, The display will show “XXX.XXX.XXX.XXX” .
6. Double click the center button to confirm or long press the center button to return to the main menu.

#### **Set Mask IP**

1. Double clicking center button to access main menu.
2. Tap the <Up/Down> button until “Options” is displayed.
3. Double clicking center button to access “Options”, Tap the <Up/Down> button to select “Service PIN” .
4. Double clicking center button to access “Service PIN” menu, Tap the <Up/Down> button to select “Set Mask IP” .
5. Double clicking center button to access “Set Mask IP”, The display will show “XXX.XXX.XXX.XXX” .
6. Double click the center button to confirm or long press the center button to return to the main menu.

#### **DHCP**

1. Double clicking center button to access main menu.
2. Tap the <Up/Down> button until “Options” is displayed.
3. Double clicking center button to access “Options”, Tap the <Up/Down> button to select “Service PIN” .
4. Double clicking center button to access “Service PIN” menu, Tap the <Up/Down> button to select “DHCP” .
5. Double clicking center button to access “DHCP”, The display will show “OFF”, Tap the <Up/Down> button to select “ON” .
6. Double click the center button to confirm or long press the center button to return to the main menu.

### **Cross Load SW**

This function allows you to update one unit from another one.

1. Double clicking center button to access main menu.
2. Tap the <Up/Down> button until “Options” is displayed.
3. Double clicking center button to access “Options”, Tap the <Up/Down> button to select “Service PIN” .
4. Double clicking center button to access “Service PIN” menu, Tap the <Up/Down> button to select “Cross Load SW” .
5. Double clicking center button to access “Cross Load SW”, The display will show “OFF”, Tap the <Up/Down> button to select “ON” .
6. Double click the center button to confirm or long press the center button to return to the main menu.

### **Clr Laser Timer**

This function allows you to clear the Laser timer.

1. Double clicking center button to access main menu.
2. Tap the <Up/Down> button until “Options” is displayed.
3. Double clicking center button to access “Options”, Tap the <Up/Down> button to select “Service PIN” .
4. Double clicking center button to access “Service PIN” menu, Tap the <Up/Down> button to select “Clr Laser Timer” .
5. Double clicking center button to access “Clr Laser Timer”, The display will show “OFF”, Tap the <Up/Down> button to select “ON” .
6. Double click the center button to confirm or long press the center button to return to the main menu.

### **Clr Error Info**

1. Double clicking center button to access main menu.
2. Tap the <Up/Down> button until “Options” is displayed.
3. Double clicking center button to access “Options”, Tap the <Up/Down> button to select “Service PIN” .
4. Double clicking center button to access “Service PIN” menu, Tap the <Up/Down> button to select “Clr Error Info” .
5. Double clicking center button to access “Clr Error Info”, The display will show “OFF”, Tap the <Up/Down> button to select “ON” .
6. Double click the center button to confirm or long press the center button to return to the main menu.

### 10.3.3. Fans Control

#### Fans Speed

With this function you can set the fans speed. The selections have Auto、Stage、Silence and Super Silence.

1. Double clicking center button to access main menu.
2. Tap the <Up/Down> button until “Options” is displayed.
3. Double clicking center button to access “Options”, Tap the <Up/Down> button to select “Fans Control” .
4. Double clicking center button to access “Fans Control” menu, Tap the <Up/Down> button to select “Fans Speed” .
5. Double clicking center button to access “Fans Speed”, The display will show “Auto”, Tap the <Up/Down> button to select “Stage”, “Silence”, “Super Silence” .
6. Double click the center button to confirm or long press the center button to return to the main menu.

#### Constant Fans

When set to ON, this setting allows the fans to be constantly on to avoid any new noise.

1. Double clicking center button to access main menu.
2. Tap the <Up/Down> button until “Options” is displayed.
3. Double clicking center button to access “Options”, Tap the <Up/Down> button to select “Fans Control” .
4. Double clicking center button to access “Fans Control” menu, Tap the <Up/Down> button to select “Constant Fans” .
5. Double clicking center button to access “Constant Fans”, The display will show “OFF”, Tap the <Up/Down> button to select “ON” .
6. Double click the center button to confirm or long press the center button to return to the main menu.

### 10.3.4. Display Setting

#### Shut off Time

With this function you can shut off the LCD display after 2 to 60minutes. The default is 5 minutes.

1. Double clicking center button to access main menu.
2. Tap the <Up/Down> button until “Options” is displayed.
3. Double clicking center button to access “Options”, Tap the <Up/Down> button to select “Display Setting” .
4. Double clicking center button to access “Display Setting” menu, Tap the <Up/Down> button to select “Shut off Time” .
5. Double clicking center button to access “Shut off Time”, The display will show “05m”, Tap the <Up/Down> button to select “02~60m” .
6. Double click the center button to confirm or long press the center button to return to the main menu.

#### Flip Display

With this function you can rotate the display by 180°.

1. Double clicking center button to access main menu.
2. Tap the <Up/Down> button until “Options” is displayed.

3. Double clicking center button to access“Options”, Tap the <Up/Down> button to select “Display Setting” .
4. Double clicking center button to access “Display Setting” menu, Tap the <Up/Down> button to select “Flip Display” .
5. Double clicking center button to access“Flip Display”, The display will show “OFF”, Tap the <Up/Down> button to select “ON” .
6. Double click the center button to confirm or long press the center button to return to the main menu.

### **Key Lock**

With this function you can activate the automatic key lock function.If this function is activated, the keys will be locked automatically after exiting the edit mode for 15 seconds.keeping press the <MODE/ESC>key for 3seconds if you do not need this function.

1. Double clicking center button to access main menu.
2. Tap the <Up/Down> button until “Options” is displayed.
3. Double clicking center button to access“Options”, Tap the <Up/Down> button to select “Display Setting” .
4. Double clicking center button to access “Display Setting” menu, Tap the <Up/Down> button to select “Key Lock” .
5. Double clicking center button to access “Key Lock”, The display will show “OFF”, Tap the <Up/Down> button to select “ON” .
6. Double click the center button to confirm or long press the center button to return to the main menu.

### **DispFlash**

When set to ON, the display will flash when in case of loss of signal.

1. Double clicking center button to access main menu.
2. Tap the <Up/Down> button until “Options” is displayed.
3. Double clicking center button to access“Options”, Tap the <Up/Down> button to select “Display Setting” .
4. Double clicking center button to access “Display Setting” menu, Tap the <Up/Down> button to select “DispFlash” .
5. Double clicking center button to access “DispFlash”, The display will show “OFF”, Tap the <Up/Down> button to select “ON” .
6. Double click the center button to confirm or long press the center button to return to the main menu.

### **10.3.5. Signal Select**

1. Double clicking center button to access main menu.
2. Tap the <Up/Down> button until “Options” is displayed.
3. Double clicking center button to access“Options”, Tap the <Up/Down> button to select “Signal Select” .
4. Double clicking center button to access“Signal Select”, The display will show “DMX”, Tap the <Up/Down> button to select “DMX”, “WDMX”, “Art-Net”, “sACN” .
5. Double click the center button to confirm or long press the center button to return to the main menu.

### **10.3.6. Temperature C/F**

With this function you can display the temperature in Celsius or Fahrenheit.

1. Double clicking center button to access main menu.
2. Tap the <Up/Down> button until “Options” is displayed.
3. Double clicking center button to access “Options”, Tap the <Up/Down> button to select “Temperature C/ F” .
4. Double clicking center button to access “Temperature C/ F”, The display will show “Celsius”, Tap the <Up/Down> button to select “Fahrenheit” .
5. Double click the center button to confirm or long press the center button to return to the main menu.

### **10.3.7. Initial Pos.**

With this function you can display initial effect position.

1. Double clicking center button to access main menu.
2. Tap the <Up/Down> button until “Options” is displayed.
3. Double clicking center button to access “Options”, Tap the <Up/Down> button to select “Initial Pos.” .
4. Double clicking center button to access “Initial Pos.”, The display will show “PAN=XXX” .
5. Double click the center button to confirm or long press the center button to return to the main menu.

### **10.3.8. Wireless DMX**

From factory, this projector is prepared for wireless data transmission (W-DMX).If you wish to de-activate W-DMX control, you can select the function “De-activate WDMX” by turning the encoder.With the function “rest” , you can log out the projector from the wireless sender.

1. Double clicking center button to access main menu.
2. Tap the <Up/Down> button until “Options” is displayed.
3. Double clicking center button to access “Options”, Tap the <Up/Down> button to select “Wireless DMX” .
4. Double clicking center button to access “Wireless DMX”, The display will show “Activate WDMX”, Tap the <Up/Down> button to select “Act&Data Out” , “Rest WDMX” .
5. Double click the center button to confirm or long press the center button to return to the main menu.

### **10.3.9. Dim Curve**

1. Double clicking center button to access main menu.
2. Tap the <Up/Down> button until “Options” is displayed.
3. Double clicking center button to access “Options”, Tap the <Up/Down> button to select “Dim Curve” .
4. Double clicking center button to access “Dim Curve”, The display will show “Square Law”, Tap the <Up/Down> button to select “Linear” .
5. Double click the center button to confirm or long press the center button to return to the main menu.

### **10.3.10. Refresh Select**

1. Double clicking center button to access main menu.

2. Tap the <Up/Down> button until “Options” is displayed.
3. Double clicking center button to access “Options”, Tap the <Up/Down> button to select “Refresh Select” .
4. Double clicking center button to access “Refresh Select”, The display will show “1.2K”, Tap the <Up/Down> button to select “2.4K”, “16K”, “25K” .
5. Double click the center button to confirm or long press the center button to return to the main menu.

#### **10.3.11. Prism Mode**

1. Double clicking center button to access main menu.
2. Tap the <Up/Down> button until “Options” is displayed.
3. Double clicking center button to access “Options”, Tap the <Up/Down> button to select “Prism Mode” .
4. Double clicking center button to access “Prism Mode”, The display will show “Full”, Tap the <Up/Down> button to select “Simple” .
5. Double click the center button to confirm or long press the center button to return to the main menu.

#### **10.3.12. Reset P/T Fade**

1. Double clicking center button to access main menu.
2. Tap the <Up/Down> button until “Options” is displayed.
3. Double clicking center button to access “Options”, Tap the <Up/Down> button to select “Reset P/T Fade” .
4. Double clicking center button to access “Reset P/T Fade”, The display will show “OFF”, Tap the <Up/Down> button to select “ON” .
5. Double click the center button to confirm or long press the center button to return to the main menu.

#### **10.3.13. Illumination Limit**

1. Double clicking center button to access main menu.
2. Tap the <Up/Down> button until “Options” is displayed.
3. Double clicking center button to access “Options”, Tap the <Up/Down> button to select “Illumination Limit” .
4. Double clicking center button to access “Illumination Limit”, The display will show “25m Distance”, Tap the <Up/Down> button to select “15m Distance”, “8m Distance” .
5. Double click the center button to confirm or long press the center button to return to the main menu.

#### **10.3.14. Trigger**

##### **DMX Value Disp.**

With this function you can display the DMX 512 value of each channel. The display automatically shows the channel with a value changing.

1. Double clicking center button to access main menu.
2. Tap the <Up/Down> button until “Options” is displayed.
3. Double clicking center button to access “Options”, Tap the <Up/Down> button to select “Trigger” .
4. Double clicking center button to access “Trigger” menu, Tap the <Up/Down> button to



select “DMX Value Disp” .

5. Double clicking center button to access “DMX Value Disp”, The display will show “PAN=.....” .
6. Double click the center button to confirm or long press the center button to return to the main menu.

### **Set To Slave**

With this function, you can define the device as slave.

1. Double clicking center button to access main menu.
2. Tap the <Up/Down> button until “Options” is displayed.
3. Double clicking center button to access “Options”, Tap the <Up/Down> button to select “Trigger” .
4. Double clicking center button to access “Trigger” menu, Tap the <Up/Down> button to select “Set To Slave” .
5. Double clicking center button to access “Set To Slave”, The display will show “Slave1” , “Slave2” , “Slave3” .
6. Double click the center button to confirm or long press the center button to return to the main menu.

### **Auto Program**

With this function, you can run the internal program. You can select the desired program under “**Select program**” . You can set the number of steps under “**Edit program**” . You can edit the individual scenes under “**Edit scenes**” . With this function, you can run the individual scenes either automatically, i.e. with the adjusted Step-Time.

1. Double clicking center button to access main menu.
2. Tap the <Up/Down> button until “Options” is displayed.
3. Double clicking center button to access “Options”, Tap the <Up/Down> button to select “Trigger” .
4. Double clicking center button to access “Trigger” menu, Tap the <Up/Down> button to select “Auto Program” .
5. Double clicking center button to access “Auto Program”, The display will show “Master” , “Alone” .
6. Double click the center button to confirm or long press the center button to return to the main menu.

#### **10.3.15. Reset Default**

With this function, you can select restore factory set for ON or OFF, the default is OFF.

1. Double clicking center button to access main menu.
2. Tap the <Up/Down> button until “Options” is displayed.
3. Double clicking center button to access “Options”, Tap the <Up/Down> button to select “Reset Default” .
4. Double clicking center button to access “Reset Default” menu, The display will show “OFF”, Tap the <Up/Down> button to select “ON” .
5. Double click the center button to confirm or long press the center button to return to the main menu.

#### **10.3.16. Reset User Set Address**

1. Double clicking center button to access main menu.
2. Tap the <Up/Down> button until “Options” is displayed.
3. Double clicking center button to access“Options”, Tap the <Up/Down> button to select “Reset User Set” .
4. Double clicking center button to access “Reset User Set” menu, Tap the <Up/Down> button to select “Address” .
5. Double clicking center button to access“Address”, The display will show“001~XXX”.
6. Double click the center button to confirm or long press the center button to return to the main menu.

### **Mode**

1. Double clicking center button to access main menu.
2. Tap the <Up/Down> button until “Options” is displayed.
3. Double clicking center button to access“Options”, Tap the <Up/Down> button to select “Reset User Set” .
4. Double clicking center button to access “Reset User Set” menu, Tap the <Up/Down> button to select “Mode” .
5. Double clicking center button to access “Mode”, The display will show “Extend Mode” .Tap the <Up/Down> button to select “Basic mode”, “Stand Mode”, “User Mode A”, “User Mode B” and “User Mode C” .
6. Double click the center button to confirm or long press the center button to return to the main menu.

### **Fans Speed**

1. Double clicking center button to access main menu.
2. Tap the <Up/Down> button until “Options” is displayed.
3. Double clicking center button to access“Options”, Tap the <Up/Down> button to select “Reset User Set” .
4. Double clicking center button to access “Reset User Set” menu, Tap the <Up/Down> button to select “Fans Speed” .
5. Double clicking center button to access“Fans Speed”, The display will show “Auto” . Tap the <Up/Down> button to select “Stage”, “Silence”, “Super Silence” .
6. Double click the center button to confirm or long press the center button to return to the main menu.

### **Constant Fans**

1. Double clicking center button to access main menu.
2. Tap the <Up/Down> button until “Options” is displayed.
3. Double clicking center button to access“Options”, Tap the <Up/Down> button to select “Reset User Set” .
4. Double clicking center button to access “Reset User Set” menu, Tap the <Up/Down> button to select “Constant Fans” .
5. Double clicking center button to access“Constant Fans”, The display will show “OFF” . Tap the <Up/Down> button to select “ON” .
6. Double click the center button to confirm or long press the center button to return to the main menu.

## **10.4.Info**

### **10.4.1. Time information**

#### **Current Time**

With this function, you can display the temporary running time of the device from the last power on. The display shows “XXXX”, “XXXX” stands for the number of hours. The counter is reset after turning the device off.

1. Double clicking center button to access main menu.
2. Tap the <Up/Down> button until “Info” is displayed.
3. Double clicking center button to access “Info”, Tap the <Up/Down> button to select “Time Info.” .
4. Double clicking center button to access “Time Info.”, Tap the <Up/Down> button to select “Current Time” .
5. Double clicking center button to access “Current Time”, The display will show “XXXX (Hours)” .
6. Double click the center button to confirm or long press the center button to return to the main menu.

#### **TtlLifeHrs**

With this function, you can display the running time of the device. The display shows “XXXX” , “XXXX” stands for the number of hours.

1. Double clicking center button to access main menu.
2. Tap the <Up/Down> button until “Info” is displayed.
3. Double clicking center button to access “Info”, Tap the <Up/Down> button to select “Time Info.” .
4. Double clicking center button to access “Time Info.”, Tap the <Up/Down> button to select “Ttl Life Hrs” .
5. Double clicking center button to access “Ttl Life Hrs”, The display will show “XXXX (Hours)” .
6. Double click the center button to confirm or long press the center button to return to the main menu.

#### **Last Run Hrs**

With this function, you can display last the running time of the device. The display shows “XXXX” , “XXXX” stands for the number of hours.

1. Double clicking center button to access main menu.
2. Tap the <Up/Down> button until “Info” is displayed.
3. Double clicking center button to access “Info”, Tap the <Up/Down> button to select “Time Info.” .
4. Double clicking center button to access “Time Info.”, Tap the <Up/Down> button to select “Last Run Hrs” .
5. Double clicking center button to access “Last Run Hrs”, The display will show “XXXX (Hours)” .
6. Double click the center button to confirm or long press the center button to return to the main menu.

#### **Laser Hours**

1. Double clicking center button to access main menu.

2. Tap the <Up/Down> button until “Info” is displayed.
3. Double clicking center button to access “Info”, Tap the <Up/Down> button to select “Time Info.” .
4. Double clicking center button to access “Time Info.”, Tap the <Up/Down> button to select “Laser Hours” .
5. Double clicking center button to access “Laser Hours”, The display will show “XXXX (Hours)” .
6. Double click the center button to confirm or long press the center button to return to the main menu.

#### **Timer PIN**

With this function, you can enter the timer password.

1. Double clicking center button to access main menu.
2. Tap the <Up/Down> button until “Info” is displayed.
3. Double clicking center button to access “Info”, Tap the <Up/Down> button to select “Time Info.” .
4. Double clicking center button to access “Time Info.”, Tap the <Up/Down> button to select “Timer PIN” .
5. Double clicking center button to access “Timer PIN”, The display will show “Password=038” .
6. Double click the center button to confirm or long press the center button to return to the main menu.

#### **Clr Last Run**

With this function, you can clear last run time of the fixture. The display shows “ON” or “OFF”, Press “Enter” to confirm.

1. Double clicking center button to access main menu.
2. Tap the <Up/Down> button until “Info” is displayed.
3. Double clicking center button to access “Info”, Tap the <Up/Down> button to select “Time Info.” .
4. Double clicking center button to access “Time Info.”, Tap the <Up/Down> button to select “Clear Last Run” .
5. Double clicking center button to access “Clear Last Run”, The display will show “OFF”, Tap the <Up/Down> button to select “ON” .
6. Double click the center button to confirm or long press the center button to return to the main menu.

#### **10.4.2. Temp.Info**

With this function you can display the temperature on the display board of the head (near CMY-filter) in Celsius.

1. Double clicking center button to access main menu.
2. Tap the <Up/Down> button until “Info” is displayed.
3. Double clicking center button to access “Info”, Tap the <Up/Down> button to select “Temp Info” .
4. Double clicking center button to access “Time Info.”, The display will show “XXX °C/ °F” .
5. Double click the center button to confirm or long press the center button to return to the main menu.

### **10.4.3. Humidity**

With this function, you can display the percentage of humidity in the unit .

1. Double clicking center button to access main menu.
2. Tap the <Up/Down> button until “Info” is displayed.
3. Double clicking center button to access “Info”, Tap the <Up/Down> button to select “Humidity.” .
4. Double clicking center button to access “Humidity.”, The display will show “x%” .
5. Double click the center button to confirm or long press the center button to return to the main menu.

### **10.4.4. Fan Info.**

With this function, you can display the fans speed.

1. Double clicking center button to access main menu.
2. Tap the <Up/Down> button until “Info” is displayed.
3. Double clicking center button to access “Info”, Tap the <Up/Down> button to select “Fan Info.” .
4. Double clicking center button to access “Fan Info.”, The display will show “xxxxRPM” .
5. Double click the center button to confirm or long press the center button to return to the main menu.

### **10.4.5. Software Ver**

With this function, you can display the software version of the device.

1. Double clicking center button to access main menu.
2. Tap the <Up/Down> button until “Info” is displayed.
3. Double clicking center button to access “Info”, Tap the <Up/Down> button to select “Software Ver” .
4. Double clicking center button to access “Software Ver”, The display will show “V1.0.....” .
5. Double click the center button to confirm or long press the center button to return to the main menu.

### **10.4.6. Network**

1. Double clicking center button to access main menu.
2. Tap the <Up/Down> button until “Info” is displayed.
3. Double clicking center button to access “Info”, Tap the <Up/Down> button to select “Network” .
4. Double clicking center button to access “Network”, The display will show “IP”, Turn the center button to select “Mask”, “Mac” .
5. Double click the center button to confirm or long press the center button to return to the main menu.

### **10.4.7. Error Info.**

1. Double clicking center button to access main menu.
2. Tap the <Up/Down> button until “Info” is displayed.
3. Double clicking center button to access “Info”, Tap the <Up/Down> button to select “Error Info.” .
4. Double clicking center button to access “Error Info.”, The display will show “IP”,

- Turn the center button to select “Error Record 1”, “.....” .
5. Double click the center button to confirm or long press the center button to return to the main menu.

## **10.5. Test**

### **10.5.1. Home**

With this function you can reset the device via the Control Board. You can select the different reset functions.

1. Double clicking center button to access main menu.
2. Tap the <Up/Down> button until “Test” is displayed.
3. Double clicking center button to access “Test”, Tap the <Up/Down> button to select “Home” .
4. Double clicking center button to access “Home”, The display will show “All” , Tap the <Up/Down> button to select “All”, “Pan&Tilt”, “Color”, “Gobo”, “Other” .
5. Double click the center button to confirm or long press the center button to return to the main menu.

### **10.5.2. Test Channel**

With this function you can test each channel’s function to ensure correct operation.

1. Double clicking center button to access main menu.
2. Tap the <Up/Down> button until “Test” is displayed.
3. Double clicking center button to access “Test”, Tap the <Up/Down> button to select “Test Channel” .
4. Double clicking center button to access “Test Channel”, The display will show “Pan”, Tap the <Up/Down> button to select other channel.
5. Double click the center button to confirm or long press the center button to return to the main menu.

### **10.5.3. Manual Control**

When set to Manual Mode, fixture will be back to factory settings.If want to adjust brightness, can adjust by shutter and dimming channel, channel value is 0-255.Other functions can be set according to user's real need.

1. Double clicking center button to access main menu.
2. Tap the <Up/Down> button until “Test” is displayed.
3. Double clicking center button to access “Test”, Tap the <Up/Down> button to select “Manual control” .
4. Double clicking center button to access “Manual control”, The display will show “PAN=XXX” .
5. Double click the center button to confirm or long press the center button to return to the main menu.

### **10.5.4. Calibration**

With this function, you can calibrate and adjust the effect wheels to their correct positions.The password of calibrate values is 050.

1. Double clicking center button to access main menu.
2. Tap the <Up/Down> button until “Test” is displayed.
3. Double clicking center button to access “Test”, Tap the <Up/Down> button to select “Calibration” .

4. Double clicking center button to access “ Calibration”, The display will show “Password=050” .
5. Double click the center button to confirm or long press the center button to return to the main menu.

#### 10.5.5. Gobo Replace

1. Double clicking center button to access main menu.
2. Tap the <Up/Down> button until “Test” is displayed.
3. Double clicking center button to access “Test”, Tap the <Up/Down> button to select “Gobo Replace” .
4. Double clicking center button to access “Gobo Replace”, The display will show “Gobo Wheel 1” .
5. Double click the center button to confirm or long press the center button to return to the main menu.

#### 10.6.Preset

1. Double clicking center button to access main menu.
2. Tap the <Up/Down> button until “Preset” is displayed.
3. Double clicking center button to access “Preset”, Tap the <Up/Down> button to select “Select prog.”, “Edit prog.”, “Edit Scenes”, “Scenes Input” .
4. Double click the center button to confirm or long press the center button to return to the main menu.

Run the auto program: A master fixture can output to three different program signals to the slave fixture to operate.It means the host will send cyclically in the following orders (The host will keep operating the program of Part 1) Then the slave fixture will make the selectively receiving according to its own set.

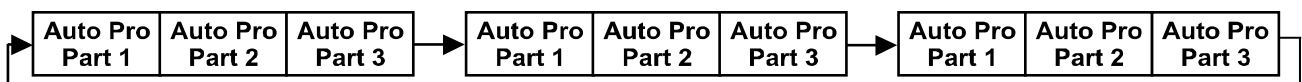

1. If the slave fixture chooses Run For Slave 1 from the menu of 1-3,then it will receive the part 1’s automatic program from link, in the same way, when the slave fixture chooses Run For Slave 2, then it will receive the part 2’s automatic program from link.
2. Enter the menu of 1-3 Function Mode---Set To Slave, Here to set machine operate which part of the program during the host-slave connection
3. Enter the menu of 1-4, 1-5 Function Mode---Set To Master
4. Enter the menu of 8-1 Edit Program---Auto Program Part1.The host outputs three groups driven program---Part1, Part2, Part3(Part1 program runs the same effect as the host)
5. Enter the menu of 8-2 Edit Program---Edit Program.Edit the program’s connection, connect the scene in order
6. The editor of the scene, there are as many as 250 scenario editors, and every scene can have a program connection of 10.

#### Note:

Part 2, Part3 repeat in accordance with the Part1’s repeat.For example: When Part 1

uses Program 2, Part 2 uses Program 4, Part 3 uses Program 6, Assume: Program 2 includes scene of 10, 11, 12, 13; Program4 includes scene of 8, 9, 10; Program 6 includes scene of 12, 13, 14, 15; Then it will run as below.

Example:

**Part 1:**

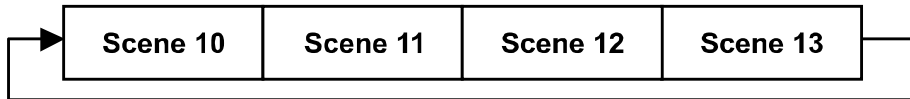

**Part 2:**

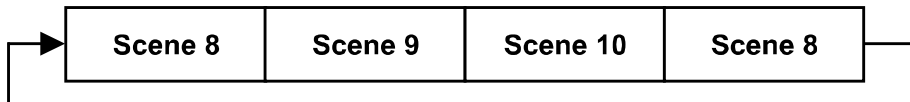

**Part 3:**

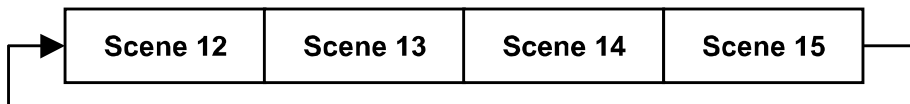

## 11. DMX PROTOCOL

<b>DMX channel's functions and their values (45DMX channels):</b>				
<b>Mode/Channel</b>			<b>Value</b>	<b>Function</b>
<b>St</b>	<b>Ba</b>	<b>Ex</b>		
1	1	1		<b>PAN Movement 8bit :</b>
			0-255	Pan Movement
2		2		<b>Pan Fine 16bit</b>
			0-255	Fine control of Pan movement
3	2	3		<b>TILT Movement 8bit :</b>
			0-255	Tilt Movement
4		4		<b>Tilt Fine 16bit</b>
			0-255	Fine control of Tilt movement
5	3	5		<b>Speed Pan/Tilt movement:</b>
			0-225	max to min speed
			226-235	blackout by movement
			236-245	blackout by all wheel changing
		246-255	no function	
6	4	6		<b>Pan Motor continuous rotation</b>



			0-63	stop rotation by spinout
			64-127	stop rotation by shortcut
			128-189	Forwards Pan rotation from fast to slow
			190-193	No rotation
			194-255	Backwards Pan rotation from slow to fast
				<b>Tilt Motor continuous rotation</b>
			0-63	stop rotation by spinout
			64-127	stop rotation by shortcut
			128-189	Forwards Tilt rotation from fast to slow
			190-193	No rotation
			194-255	Backwards Tilt rotation from slow to fast
				<b>Shutter, strobe:</b>
			0-10	Shutter closed
			11-20	No function (shutter open)
			21-117	Strobe effect slow to fast
			118-126	No function (shutter open)
			127-180	Pulse-effect in sequences
			181-191	No function (shutter open)
			192-245	Random strobe effect slow to fast
			246-255	No function (shutter open)
				<b>Dimmer intensity:</b>
			0-255	Intensity 0 to 100%
				<b>Fine Dimmer intensity:</b>
			0-255	Dimmer intensity fine
				<b>CTO Color :</b>
			0-255	CTO (0-white, 255-100% CTO)
				<b>CTO Color Fine :</b>
			0-255	CTO Fine
				Reserved
				<b>Zoom :</b>
			0-255	Zoom adjustment from small to big
				<b>Zoom Fine:</b>
			0-255	Zoom adjustment Fine
				<b>Focus :</b>
			0-255	Continuous adjustment from near to far
				<b>Focus Fine:</b>
			0-255	Continuous adjustment Fine
				<b>Auto Focus :</b>
			0-50	Auto Focus Off
			51-100	5m
			101-150	7.5m

			151-200	10m
			201-255	15m
16	14	19		<b>AutoFocus Fine:</b>
			0-255	Continuous adjustment Fine
17	15	20		<b>Zoom mode:</b>
			0-84	Beam mode
			85-169	Spot mode
			170-255	Special mode
18	16	21		<b>Color Wheel :</b>
			0-63	CTO (0-white, 63-100% CTO)
			64	Color 1
			65	Color 2
			66	Color 3
			67	Color 4
			68	Color 5
			69	Color 6
			70	Color 7
			71	Color 8
			72	Color 9
			73	Color 10
			74	Color 11
			75	Color 12
			76	Color 13
			77	Color 14
			78	Color 15
			79	Color 16
			80	Color 17
			81	Color 18
			82	Color 19
			83	Color 20
			84	Color 21
			85	Color 22
			86	Color 23
			87	Color 24
			88	Color 25
			89	Color 26
			90	Color 27
			91-127	unused
			128-189	Forwards rainbow effect from fast to slow
			190-193	No rotation
			194-255	Backwards rainbow effect from slow to fast

		22		<b><u>Color Wheel Fine:</u></b>
			0-255	Color Wheel colour change to any position Fine
19	17	23		<b><u>Cyan Color :</u></b>
			0-255	Cyan (0-white, 255-100% Cyan)
		24		<b><u>Cyan Color Fine :</u></b>
			0-255	Cyan Fine
20	18	25		<b><u>Magenta Color :</u></b>
			0-255	Magenta (0-white, 255-100% magenta)
		26		<b><u>Magenta Color Fine :</u></b>
			0-255	Magenta Fine
21	19	27		<b><u>Yellow Color :</u></b>
			0-255	Yellow (0-white, 255-100% Yellow)
		28		<b><u>Yellow Color Fine :</u></b>
			0-255	Yellow Fine
				<b><u>Rotating gobos, cont. rotation :</u></b>
			0-9	Open
			10-13	Rot. gobo 1
			14-17	Rot. gobo 2
			18-21	Rot. gobo 3
			22-25	Rot. gobo 4
			26-29	Rot. gobo 5
			30-33	Rot. gobo 6
			34-37	Rot. gobo 7
			38-41	Rot. gobo 8
			42-45	Rot. gobo 9
			46-49	Rot. gobo 10
			50-53	Rot. gobo 11
22	20	29	54-57	Rot. gobo 12
			58-68	Gobo 1 shake slow to fast
			69-79	Gobo 2 shake slow to fast
			80-90	Gobo 3 shake slow to fast
			91-101	Gobo 4 shake slow to fast
			102-112	Gobo 5 shake slow to fast
			113-123	Gobo 6 shake slow to fast
			124-134	Gobo 7 shake slow to fast
			135-145	Gobo 8 shake slow to fast
			146-156	Gobo 9 shake slow to fast
			157-167	Gobo 10 shake slow to fast
			168-178	Gobo 11 shake slow to fast
			179-189	Gobo 12 shake slow to fast
			190-221	Gobo wheel rotation forwards from fast to slow

			222-223	No rotation
			224-255	Gobo wheel rotation f backwards from slow to fast
23	21	30		<b>Rotating gobo index,rotating gobo rotation 1:</b>
			0-127	Gobo indexing
			128-189	Forwards gobo rotation from fast to slow
			190-193	No rotation
			194-255	Backwards gobo rotation from slow to fast
		31		<b>Rotating gobo indexing Fine :</b>
			0-255	Fine indexing
24	22	32		<b>Fixed Gobo:</b>
			0-2	Open
			3-14	Forwards rotation from fast to slow
			15-17	No rotation
			18-29	Backwards rotation from slow to fast
			30	Gobo 1
			31	Gobo 2
			32	Gobo 3
			33	Gobo 4
			34	Gobo 5
			35	Gobo 6
			36	Gobo 7
			37	Gobo 8
			38	Gobo 9
			39	Gobo 10
			40	Gobo 11
			41	Gobo 12
			42	Gobo 13
			43	Gobo 14
			44	Gobo 15
			45	Gobo 16
			46	Gobo 17
			47	Gobo 18
			48	Gobo 19
			49	Gobo 20
			50	Gobo 21
			51	Gobo 22
52	Gobo 23			
53	Gobo 24			
54	Gobo 25			
55	Gobo 26			
56	Gobo 27			

57	Gobo 28
58	Gobo 29
59	Gobo 30
60	Gobo 31
61	Gobo 32
62	Gobo 33
63	Gobo 34
64	Gobo 35
65	Open
66	Gobo 36
67	Gobo 37
68	Gobo 38
69	Gobo 39
70	Gobo 40
71	Gobo 41
72	Gobo 42
73	Gobo 43
74	Gobo 44
75	Gobo 45
76	Gobo 46
77	Gobo 47
78	Gobo 48
79	Gobo 49
80	Gobo 50
81	Gobo 51
82	Gobo 52
83	Gobo 53
84	Gobo 54
85	Gobo 55
86	Gobo 56
87	Gobo 57
88	Gobo 58
89	Gobo 59
90	Gobo 60
91	Gobo 61
92	Gobo 62
93	Gobo 63
94	Gobo 64
95	Open
96	Gobo 65
97	Gobo 66

98	Gobo 67
99	Gobo 68
100	Gobo 69
101	Gobo 70
102	Gobo 71
103	Gobo 72
104	Gobo 73
105	Gobo 74
106	Gobo 75
107	Gobo 76
108	Gobo 77
109	Gobo 78
110	Gobo 79
111	Gobo 1 shake slow to fast
112	Gobo 2 shake slow to fast
113	Gobo 3 shake slow to fast
114	Gobo 4 shake slow to fast
115	Gobo 5 shake slow to fast
116	Gobo 6 shake slow to fast
117	Gobo 7 shake slow to fast
118	Gobo 8 shake slow to fast
119	Gobo 9 shake slow to fast
120	Gobo 10 shake slow to fast
121	Gobo 11 shake slow to fast
122	Gobo 12 shake slow to fast
123	Gobo 13 shake slow to fast
124	Gobo 14 shake slow to fast
125	Gobo 15 shake slow to fast
126	Gobo 16 shake slow to fast
127	Gobo 17 shake slow to fast
128	Gobo 18 shake slow to fast
129	Gobo 19 shake slow to fast
130	Gobo 20 shake slow to fast
131	Gobo 21 shake slow to fast
132	Gobo 22 shake slow to fast
133	Gobo 23 shake slow to fast
134	Gobo 24 shake slow to fast
135	Gobo 25 shake slow to fast
136	Gobo 26 shake slow to fast
137	Gobo 27 shake slow to fast
138	Gobo 28 shake slow to fast

139	Gobo 29 shake slow to fast
140	Gobo 30 shake slow to fast
141	Gobo 31 shake slow to fast
142	Gobo 32 shake slow to fast
143	Gobo 33 shake slow to fast
144	Gobo 34 shake slow to fast
145	Gobo 35 shake slow to fast
146	Gobo 36 shake slow to fast
147	Gobo 37 shake slow to fast
148	Gobo 38 shake slow to fast
149	Gobo 39 shake slow to fast
150	Gobo 40 shake slow to fast
151	Gobo 41 shake slow to fast
152	Gobo 42 shake slow to fast
153	Gobo 43 shake slow to fast
154	Gobo 44 shake slow to fast
155	Gobo 45 shake slow to fast
156	Gobo 46 shake slow to fast
157	Gobo 47 shake slow to fast
158	Gobo 48 shake slow to fast
159	Gobo 49 shake slow to fast
160	Gobo 50 shake slow to fast
161	Gobo 51 shake slow to fast
162	Gobo 52 shake slow to fast
163	Gobo 53 shake slow to fast
164	Gobo 54 shake slow to fast
165	Gobo 55 shake slow to fast
166	Gobo 56 shake slow to fast
167	Gobo 57 shake slow to fast
168	Gobo 58 shake slow to fast
169	Gobo 59 shake slow to fast
170	Gobo 60 shake slow to fast
171	Gobo 61 shake slow to fast
172	Gobo 62 shake slow to fast
173	Gobo 63 shake slow to fast
174	Gobo 64 shake slow to fast
175	Gobo 65 shake slow to fast
176	Gobo 66 shake slow to fast
177	Gobo 67 shake slow to fast
178	Gobo 68 shake slow to fast
179	Gobo 69 shake slow to fast

			180	Gobo 70 shake slow to fast
			181	Gobo 71 shake slow to fast
			182	Gobo 72 shake slow to fast
			183	Gobo 73 shake slow to fast
			184	Gobo 74 shake slow to fast
			185	Gobo 75 shake slow to fast
			186	Gobo 76 shake slow to fast
			187	Gobo 77 shake slow to fast
			188	Gobo 78 shake slow to fast
			189	Gobo 79 shake slow to fast
			190-221	Clock-wise scroll from fast to slow
			222-223	Reserved
			224-255	Counter clock-wise scroll from slow to fast
				<b><u>Prism 1, Frost:</u></b>
			0-40	Open
			41-83	Prism 1
			84-126	Prism 2
			127-169	Prism 3
			170-212	Prism 4
			213-255	Frost
				<b><u>Rotating prism index, rotating prism rotation 1</u></b>
			0-127	Prism indexing
			128-189	Forwards prism rotation from fast to slow
			190-193	No rotation
			194-255	Backwards prism rotation from slow to fast
				<b><u>Rotating prism indexing Fine 1:</u></b>
			0-255	Fine indexing
				<b><u>Prism 2, Frost:</u></b>
			0-40	Open
			41-83	Prism 1
			84-126	Prism 2
			127-169	Prism 3
			170-212	Prism 4
			213-255	Frost
				<b><u>Rotating prism index, rotating prism rotation 2</u></b>
			0-127	Prism indexing
			128-189	Forwards prism rotation from fast to slow
			190-193	No rotation
			194-255	Backwards prism rotation from slow to fast
				<b><u>Rotating prism indexing Fine 2:</u></b>
			0-255	Fine indexing
25	23	33		
26	24	34		
27	25	36		
28	26	37		
		38		



29	27	39		<b><u>Pan degree blackout coarse</u></b>
			0-255	
30	28	40		<b><u>Pan degree blackout fine</u></b>
			0-255	
31	29	41		<b><u>Pan black out size</u></b>
			0-255	0 to 100% : size of the black out zone
32	30	42		<b><u>Tilt degree blackout coarse</u></b>
			0-255	
33	31	43		<b><u>Tilt degree blackout fine</u></b>
			0-255	
34	32	44		<b><u>Tilt black out size</u></b>
			0-255	0 to 100% : size of the black out zone
35	33	45		<b><u>Control, reset, internal programs:</u></b>
			0-4	unused
			5-9	Display Off
			10-14	Display On
			15-19	Display Invert Off
			20-24	Display Invert On
			25-26	Auto fan control mode
			27-28	Stage fan control mode
			29-30	Silence fan control mode
			31-32	Super Silence fan control mode
			33-34	Constant Fans Off
			35-36	Constant Fans On
			37-44	unused
			45-49	Square Law
			50-54	Linear
			55-57	1.2K
			58-60	2.4K
			61-63	16K
			64-69	25K
			70-74	Prism Mode Simple
			75-79	Prism Mode Full
			80-84	All motor reset
			85-87	Scan motor reset
			88-90	Colors motor reset
			91-93	Gobo motor reset
94	unused			
95	Reset P/T Fade Off			
96	Reset P/T Fade On			
97-99	Other motor reset			

	100-102	unused
	103-105	unused
	106-108	CMY speed Slow
	109-111	CMY speed Medium
	112-114	CMY speed Fast
	115-117	Prerig INIT Off
	118-120	Prerig INIT On
	121-123	Pan Degree 540°
	124-126	Pan Degree 630°
	127-129	Tilt Degree 540°
	130-132	Tilt Degree 270°
	133-135	CTO Control: Color Wheel
	136-138	CTO Control: Separate Ch
	139-141	Illumination Limit: 25m Distance
	142-144	Illumination Limit: 15m Distance
	145-147	Illumination Limit: 8m Distance
	148-255	unused

## 12. ERROR MESSAGES

When you turn on the device, it will first perform a reset. The display may show “Err channel is XX” should there be problems with one or more functions. “XX” stands for channel 1, 2, 3, 4, 5, 6 etc whose sensor has encountered a problem. For example, when the display shows “Err channel is Pan movement”, it means there is an error on channel 1. If there are errors on channel 1, channel 3, channel 6 at the same time, you may see the error message, “Err channel is Pan movement”, “Err channel is Tilt movement” “Err channel is Shutter”, flash twice, and then the device will generate a second reset. If the error messages persist after performing a reset more than twice, the channels which have errors may not work properly however, all other functions can work as usual. Please contact your dealer or manufacturer for service. Self repair is not allowed.

### **PAN- movement Er**

(PAN- yoke movement error) This message will appear after the reset of the fixture if the yoke’s magnetic-indexing circuit malfunction (Optical Sensor or Magnetic Sensor fails) or the stepper motor is defective (or its driving IC on the main PCB). The PAN-movement is not located in the default position after the reset.

### **TILT- movement Er**

(TILT- head movement error) This message will appear after the reset of the fixture if the head’s magnetic-indexing circuit malfunctions ((Optical Sensor or Magnetic Sensor fails)) or the stepper motor is defective (or its driving IC on the main PCB). The TILT-movement is not located in the default position after the reset.

### **Zoom wheel Er**

(Zoomwheel error) This message will appear after the reset of the fixture if the head’s magnetic-indexing circuit malfunctions (Optical Sensor or Magnetic Sensor fails) or the stepper motor is defective (or its driving IC on the main PCB). The Zoom -movement is not located in the default position after the reset.

### **Focus wheel Er**

(Focuswheel error) This message will appear after the reset of the fixture if the head’s magnetic-indexing circuit malfunctions (Optical Sensor or Magnetic Sensor fails) or the stepper motor is defective (or its driving IC on the main PCB). The Focus -movement is not located in the default position after the reset.

### **Color wheel Er**

(Colorwheel- error) This message will appear after the reset of the fixture if the head’s magnetic-indexing circuit malfunctions (sensor failed or magnet missing) or the stepper motor is defective (or its driving IC on the main PCB). The Color - movement is not located in the default position after the reset.

### **Cyan Color wheelEr**

(Cyan Color wheel- error) This message will appear after the reset of the fixture if the head’s magnetic-indexing circuit malfunctions (sensor failed or magnet missing) or the stepper motor is defective (or its driving IC on the main PCB). The CMY -movement is not located in the default position after the reset.

### **Magenta Color wheelEr**

(Magenta Color wheel- error) This message will appear after the reset of the fixture if the head's magnetic-indexing circuit malfunctions (sensor failed or magnet missing) or the stepper motor is defective (or its driving IC on the main PCB).The CMY -movement is not located in the default position after the reset.

**Yellow Color wheel Er**

(Yellow Color wheel- error) This message will appear after the reset of the fixture if the head's magnetic-indexing circuit malfunctions (sensor failed or magnet missing) or the stepper motor is defective (or its driving IC on the main PCB).The CMY -movement is not located in the default position after the reset.

**Rot\_Gobo wheel Er**

(Rot\_Gobo1wheel - error) This message will appear after the reset of the fixture if the head's magnetic-indexing circuit malfunctions (sensor failed or magnet missing) or the stepper motor is defective (or its driving IC on the main PCB).The Rot\_Gobo1 - movement is not located in the default position after the reset.

**Fix\_Gobo wheel Er**

(Fix\_Gobowheel - error) This message will appear after the reset of the fixture if the head's magnetic-indexing circuit malfunctions (sensor failed or magnet missing) or the stepper motor is defective (or its driving IC on the main PCB).The Fix\_Gobo - movement is not located in the default position after the reset.

**Prism wheelEr**

(Prism wheel- error) This message will appear after the reset of the fixture if the head's magnetic-indexing circuit malfunctions (sensor failed or magnet missing) or the stepper motor is defective (or its driving IC on the main PCB).The Prism - movement is not located in the default position after the reset.

**Frost wheelEr**

(Frost wheel - error) This message will appear after the reset of the fixture if the head's magnetic-indexing circuit malfunctions (sensor failed or magnet missing) or the stepper motor is defective (or its driving IC on the main PCB).TheFrost - movement is not located in the default position after the reset.

## **13. CLEANING AND MAINTENANCE**



**CAUTION!**

**ALWAYS RUN AN IP TEST USING THE AYRTON IP TEST KIT FOLLOWING ANY MAINTENANCE OPERATION! FAILURE TO COMPLY WITH THIS CLAUSE WILL VOID THE WARRANTY!**



**CAUTION!**

**THE OPERATOR MUST FOLLOW STRICTLY THE VACUUM AND PRESSURE SETTING VALUES AS BELOW, OR USE THE CORRESPONDING PRESET FIXTURE MENU TO RUN THE IP TEST. ANY OVERPRESSURE OPERATION MAY CAUSE ACCIDENTAL DAMAGE OR INJURY.**

	Minimum value		Maximum value		Steady time (Hold time)
	Kpa	Psi	Kpa	Psi	
<b>Vacuum</b>	-35	-5.08	-40	5.80	10
<b>Pressure</b>	25	3.63	30	4.35	10

Once the covers removed and before set them back, check the cover gasket to avoid any leak due to gasket damage.

**Cross tightening the covers HEX screws at the right torque value.**

Use a **Torque Screwdriver** set at **1,4Nm** (12,4in/lbf) to fasten correctly the (10) HEX head screws for each cover.

The following points have to be considered during inspection:

- 1) All screws for installing the devices or parts of the device have to be tightly connected and must not be corroded.
- 2) There must not be any deformations to the housing, lenses, rigging and installation points (ceiling, suspension, trussing).
- 3) Motorized parts must not show any signs of wear and must move smoothly without issue.
- 4) The power supply cables must not show any damage, material fatigue or sediment.

Further instructions depending on the installation location and usage have to be adhered to by a qualified installer and any safety concerns have to be removed.



**CAUTION!**

**Disconnect from mains before starting maintenance operation.**

In order to ensure the device remains in good condition and does not fail prematurely, we suggest regular maintenance.

- 1) Clean the outside lens each week to avoid loss of output due to accumulation of dust/ dirt on the lens.

- 2) Clean the fans each week to ensure maximum airflow and efficient thermal cooling. This will ensure the light source is operated in the best possible condition.
- 3) A detailed electrical check by an approved electrician every quarter to make sure that the circuit contacts are in good condition. This will prevent poor circuit contacts and the resultant overheating.

We recommend frequent cleaning of the device. Please use a moist, lint-free cloth. Never use alcohol or solvents.

Please refer to the instructions under “Installation instructions” .

Should you need any spare parts, please order genuine parts from your local dealer.

**Remark:** Errors and omissions for all information given in this manual are excepted. All information is subject to change without prior notice.



Use the Ayrton IP TEST KIT to control the IP rating of the fixture.



