

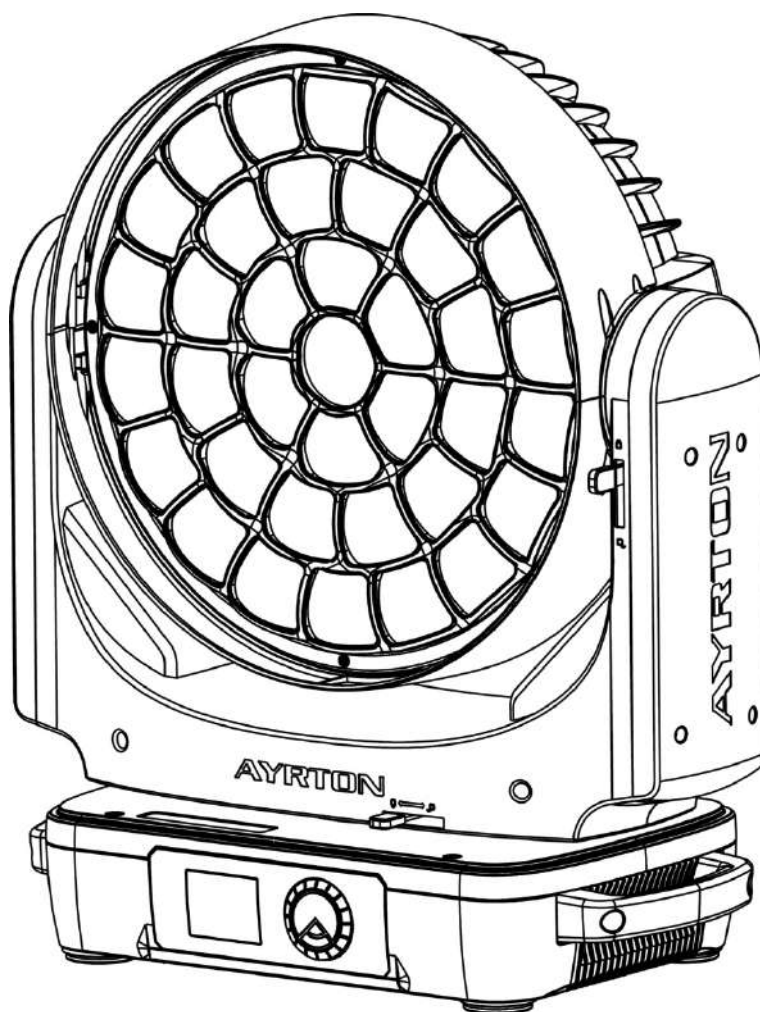

*User Manual*



**zonda<sup>9</sup>**  
**WASH**

KEEP THIS MANUAL FOR FUTURE NEEDS **CE**

## CONTENTS

<b>1. SAFETY INSTRUCTIONS</b>	<b>2</b>
<b>2. FEATURES</b>	<b>4</b>
<b>3. FIXTURE OVERVIEW</b>	<b>6</b>
<b>4. DIMENSIONAL DRAWINGS</b>	<b>7</b>
<b>5. INSTALLATION INSTRUCTIONS</b>	<b>8</b>
<b>6. DMX-512 CONTROL CONNECTION</b>	<b>11</b>
<b>7. DMX-512 CONNECTION WITH DMX TERMINATOR</b>	<b>11</b>
<b>8. DEVICE DMX START ADDRESS SELECTION</b>	<b>12</b>
<b>9. DISPLAY</b>	<b>12</b>
<b>10. DMX PROTOCOL</b>	<b>31</b>
<b>11. ERROR MESSAGES</b>	<b>37</b>
<b>12. CLEANING AND MAINTENANCE</b>	<b>38</b>

# 1. SAFETY INSTRUCTIONS

## 1.1 IMPORTANT SAFETY WARNING

This device has left the factory in perfect condition. In order to maintain this condition and to ensure safe operation, it is absolutely necessary for the user to follow the safety instructions and warning notes written in this user manual.

In order to install, operate, and maintain the lighting fixture safely and correctly we suggest that the installation and operation be carried out by qualified technicians and these instructions be carefully followed.

	<b>CAUTION!</b> HIGH VOLTAGE. RISK OF SEVERE OR FATAL ELECTRIC SHOCK
---	---

	<b>CAUTION!</b> ALWAYS DISCONNECT MAINS SUPPLY BEFORE REMOVING ANY FIXTURE COVERS
---	--

	<b>CAUTION!</b> NEVER LOOK DIRECTLY INTO THE LIGHT SOURCE. SENSITIVE PERSONS MAY SUFFER AN EPILEPTIC SHOCK
--	---

	<b>CAUTION!</b> NEVER TOUCH THE DEVICE DURING OPERATION! COVERS MAY BE HOT
---	---

<b>CAUTION!</b>	
	<b>Warning:</b> Changes or modifications to this unit not expressly approved by the party responsible for compliance could void the user's authority to operate the equipment.
	<b>NOTE:</b> This equipment has been tested and found to comply with the limits for a Class A digital device, pursuant to Part 15 of the FCC Rules. These limits are designed to provide reasonable protection against harmful interference when the equipment is operated in a commercial environment. This equipment generates, uses and can radiate radio frequency energy and, if not installed and used in accordance with the instruction manual, may cause harmful interference to radio communications. Operation of this equipment in a residential area is likely to cause harmful interference in which case the user will be required to correct the interference at his own expense.

### *Important:*



***Damage caused by the disregard of this user manual is not subject to warranty. The dealer and manufacturer will not accept liability for any resulting defects or problems.***

- If the device has been exposed to temperature changes due to environmental conditions, do not power on immediately. The resulting condensation could damage the device. Leave the device powered off until it has reached room temperature.
- This device falls under protection-class I. Therefore, it is essential that the device be earthed.
- If either lenses or display are damaged (damage may include cracks or gashes in the

material) they must be replaced.

- Electrical connections, such as replacing the power plug, must be performed by a qualified person.
- Make sure that the available voltage is not higher than that which is stated in this manual.
- Make sure the power cord is never crushed or damaged by sharp edges. If this should be the case, replacement of the cable must be done by an authorized dealer.
- If the external flexible power cord of this device is damaged, it shall be exclusively replaced by the manufacturer or their service agent or a similar qualified person in order to avoid injury.
- When the device is not in use or before performing maintenance, always disconnect the device from the mains. Only handle the power cord from the plug. Never pull the plug out of a socket by tugging the power cord.
- When powered on for the first time, some smoke or smell may occur. This is caused by coating on metal parts when heated and is normal. If you are concerned, please contact your distributor.
- Do not focus the beam onto flammable surfaces. The minimum distance between the exiting lens of the device and the illuminated surface must be greater than 1 meter.

**Please be aware that damage caused by any modifications to the device are not subject to warranty. Keep away from children and non-professionals.**

## 1.2 GENERAL GUIDELINES

- This device is a lighting effect for professional use on stages, in discotheques, theatres, etc. the device was designed for indoor use only.
- This fixture is only allowed to be operated within the maximum alternating current as stated in the technical specifications in section 2 of this manual.
- Handle the device with care, avoid shaking or using force when installing or maintaining the device.
- If you use the quick lock cam when rigging the device, make sure the quick lock fasteners are located in the quick lock holes correctly and securely.
- Operate the device only after having familiarized yourself with its functions. Do not permit operation by persons not qualified for operating the device. Most damage is the result of unprofessional operation.
- Please use the original packaging if the device is to be transported.
- The applicable temperature for the device is between -10°C to 45°C. Do not use the device outside of this temperature range.
- The light source of this luminaire is not replaceable; when the light source reaches its end of life the whole luminaire shall be replaced.

**For safety reasons, please be aware that all modifications to the device are forbidden.**

**If this device is operated in any way different to the ones described in this manual, the product may suffer damage and the warranty becomes void. Furthermore, any other operation may lead to short-circuits, burns, electric shocks etc.**

## 1.3 NOTE

- Before packing and transportation, please make sure the 2 zoom locks are engaged as shown below:

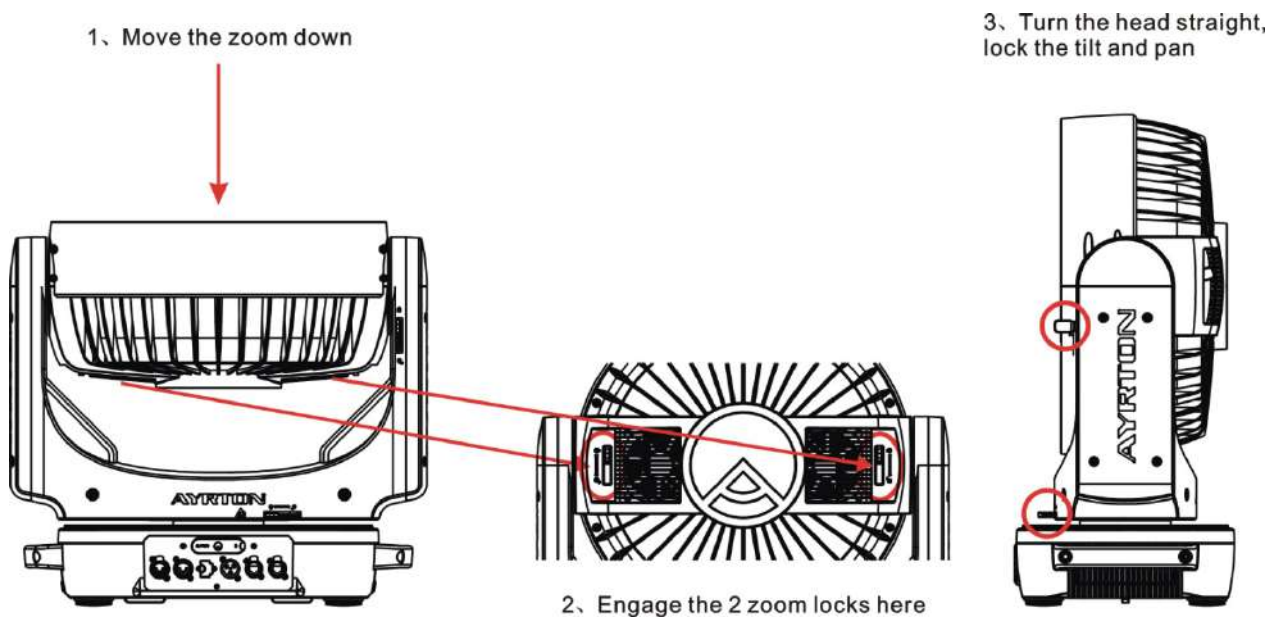

- Please unlock all the above mentioned locks before powering on the fixture.

## 2. FEATURES

### POWER SUPPLY

- AC120-240V~, 50/60Hz
- Power Consumption: 1400W

### LIGHT SOURCE

- LED: 37 pcs 4 in 1 RGBW LEDs
- Extremely long Life: >20,000H

### MOVEMENT

- Pan movement: 540° /630° Optional (16 bit)
- Tilt movement: 270° (16 bit)
- Advanced moving system: fast, stable and quite, auto x-y repositioning

### COLORS

- Excellent color mixing and rainbow effect

### FEATURES

- 3 Control channel modes: 26/26/63 channels
- 2 Operation modes: DMX-512, Master / Slave mode
- Strobe effect with 1-25 flashes per second and pulse effect
- Dimmer: 0%~100% full range dimming

### DISPLAY

- Advanced and convenient full –color LCD
- Can be changed 180° reverse to fit for different installation position

## SOFTWARE

Upgrades: fast and convenient through DMX cable with DMX-512 controller

Reset DMX address, remote lamp control, reset can all be done by the DMX controller

Running time of fixture on display for reference

## OTHER SPEC

Input signal isolation: guarantees stable signal transmission without interference

Advanced RDM function

## WEIGHT

Net weight: 29 kg

## DMX CHANNEL CHART

%	1	2	3	4	5	6	7	8	9	10	11	12	13	14	15
	Pan	Pan Fine	Tilt	Tilt Fine	Scan Speed	Pan Motor	Tilt Motor	Red LED-all arrays	Red fine LED-all arrays	Green LED-all arrays	Green fine LED-all arrays	Blue LED-all arrays	Blue fine LED-all arrays	White LED-all arrays	White fine LED-all arrays
100%		16bit Pan Fine		16bit Tilt Fine	No Function	Backwards Pan rotation from slow to fast	Backwards Tilt rotation from slow to fast								
75%					Blackout by movement	No rotation	No rotation								
50%					Moving speed ↑ Min	Forwards Pan rotation from fast to slow	Forwards Tilt rotation from fast to slow								
25%						Shortcut	Shortcut								
0%					Max	Shortcut	Shortcut								

%	16	17	18	19	20	21	22	23	24	25	26
	Strobe	Dimming	Dimming fine intensity	Linear CTO from 8000 to 2700K	Color Presets	Color Presets/ RGBW cross fade	Between Color Preset cross fade	Zoom	Zoom Fine	Reserved	Reset
100%				2700K	See Appendix	Output controlled by color preset values	Cross fade between 2color presets from 100ms to 5sec		Fine control for Zoom adjustment	Reserved	Zoom motor reset
75%				3500K		Output controlled by RGBW values		No fade			
50%				4000K							Tungsten lamp simulation off
25%				4500K							Tungsten lamp simulation 500W
0%				5000K							Tungsten lamp simulation 250W
				5500K							Tungsten lamp simulation 100W
				6000K							Tungsten lamp simulation 50W
				6500K							25K
				7000K				16K			
				7500K				12K			
				8000K				Linear			
				No function				Square Law			
								Unused			
								Constant Fans On			
								Constant Fans Off			
								Super Silence fan control mode			
								Silence fan control mode			
								Stage fan control mode			
								Auto fan control mode			
								Display Invert On			
								Display Invert Off			
								Display On			
								Display Off			
								Unused			

### 3. FIXTURE OVERVIEW

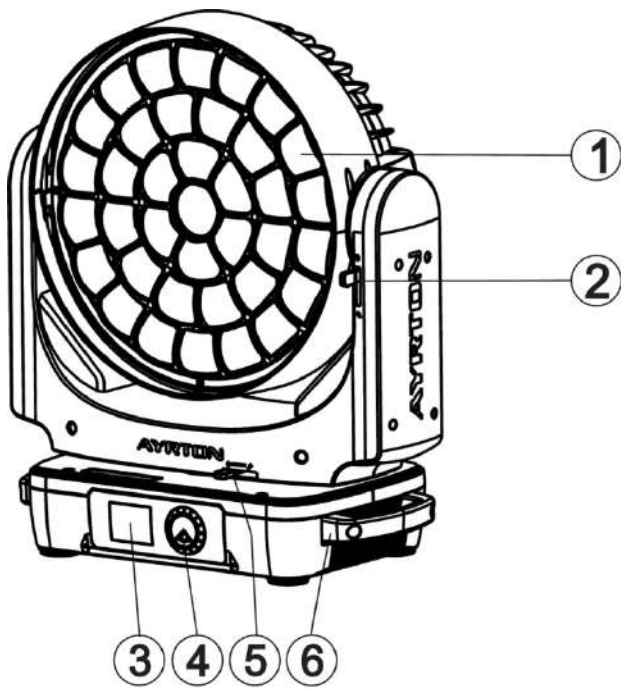

- 1) Lenses Assembly
- 2) Tilt Lock
- 3) Display
- 4) Clicking Jog Wheel
- 5) Pan Lock
- 6) Handle

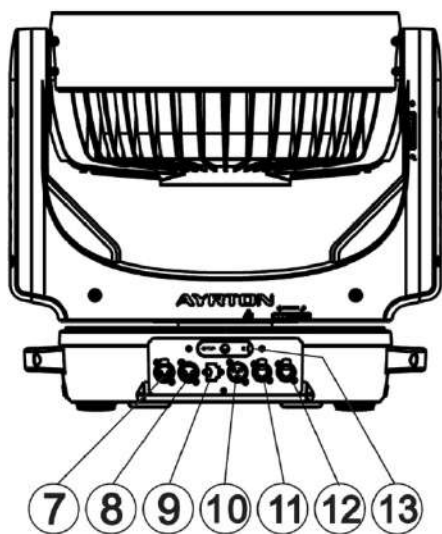

- 7) DMX Out
- 8) DMX In
- 9) USB
- 10) Power In
- 11) RJ45 Out
- 12) RJ45 In
- 13) Battery

## 4. DIMENSIONAL DRAWINGS

### 4.1. Fixture Dimension

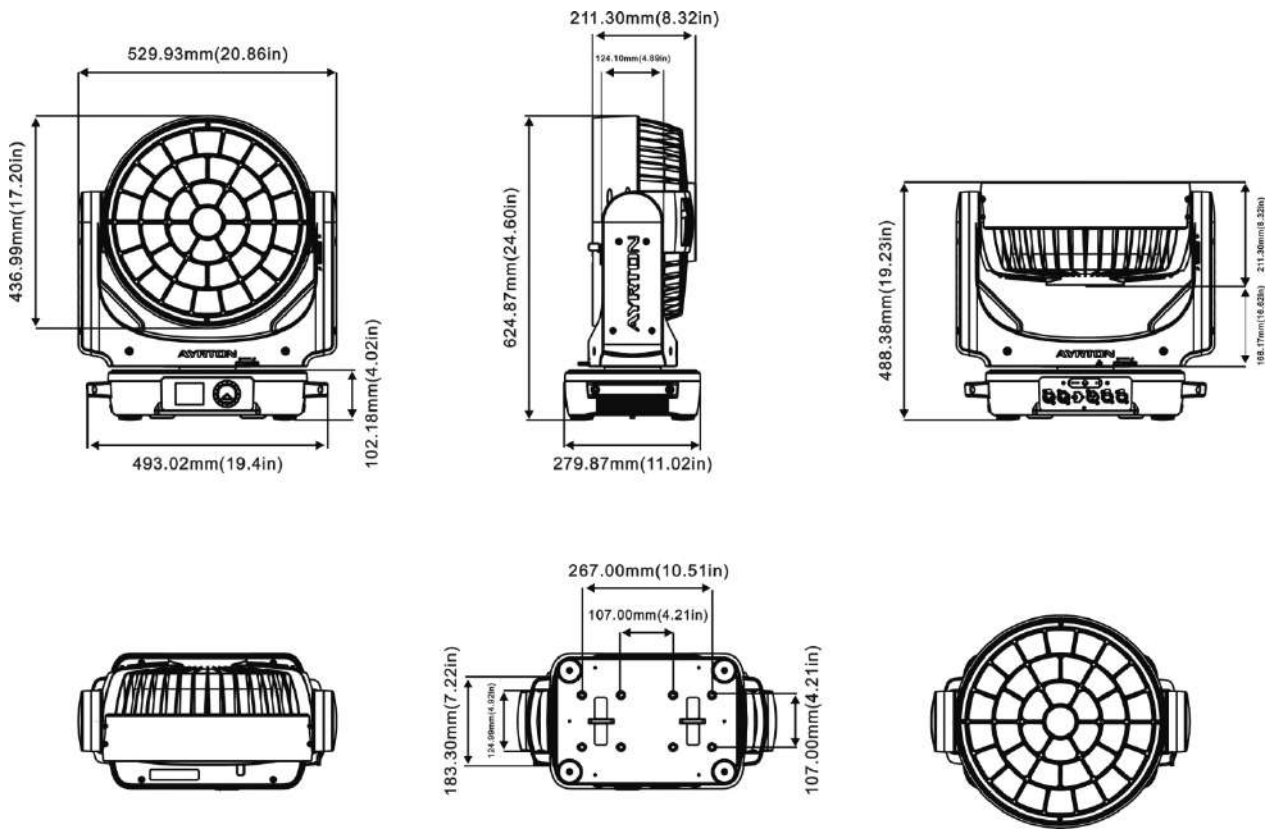



## 5. INSTALLATION INSTRUCTIONS

### 5.1. Rigging the device



#### **CAUTION!**

PLEASE CONSIDER THE RESPECTIVE NATIONAL NORMS DURING INSTALLATION. THE INSTALLATION MUST ONLY BE CARRIED OUT BY A QUALIFIED PERSON.

- The applicable temperature for the lighting is between -10°C to 45°C. Do not use the lighting under or above the temperature.
- The installation of the effect has to be built and constructed in a way that it can hold 10 times the weight for 1 hour without any harming deformation.
- The installation must always be secured with a secondary safety attachment, e.g. an appropriate safety rope.
- Never stand directly below the device when mounting, removing or servicing the fixture.
- The operator has to make sure the safety relating and machine technical installations are approved by an expert before taking the device into operation for the first time.
- These installations have to be approved by a skilled person once a year.
- Overhead mounting requires extensive experience, including amongst others calculating working load limits, installation material being used, and periodic safety inspection of all installation material and the device. If you lack these qualifications, do not attempt the installation yourself. Improper installation can result in bodily injury.

## 5.2. Rigging using the omega brackets

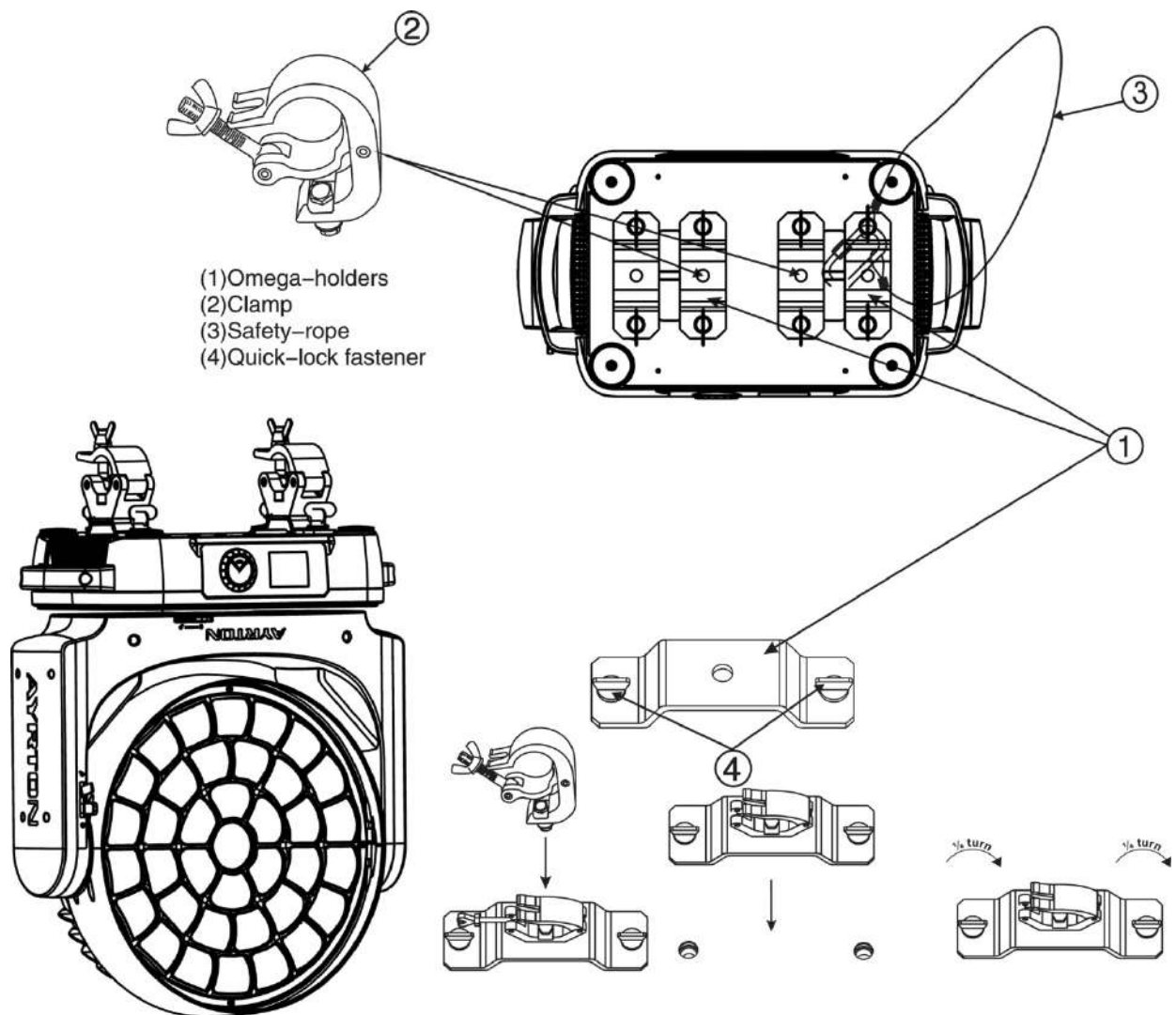

- Fix the clamp to the bracket by tightening the M12 nut and bolt to the bracket through the  $\Phi 13$  hole in the middle of the bracket.
- Insert the quick-lock fasteners of the first Omega holder into the respective holes on the bottom of the device. Tighten the quick-lock fasteners fully clockwise.
- Install the second Omega holder.
- Pull the safety cable through the holes on the bottom of the base and over the trussing system or another suitable rigging point. Insert the end into the carabiner and tighten the safety screw.



### Important:

This step is very important to ensure safe rigging of the fixture.

### 5.3. RIGGING DRAWINGS

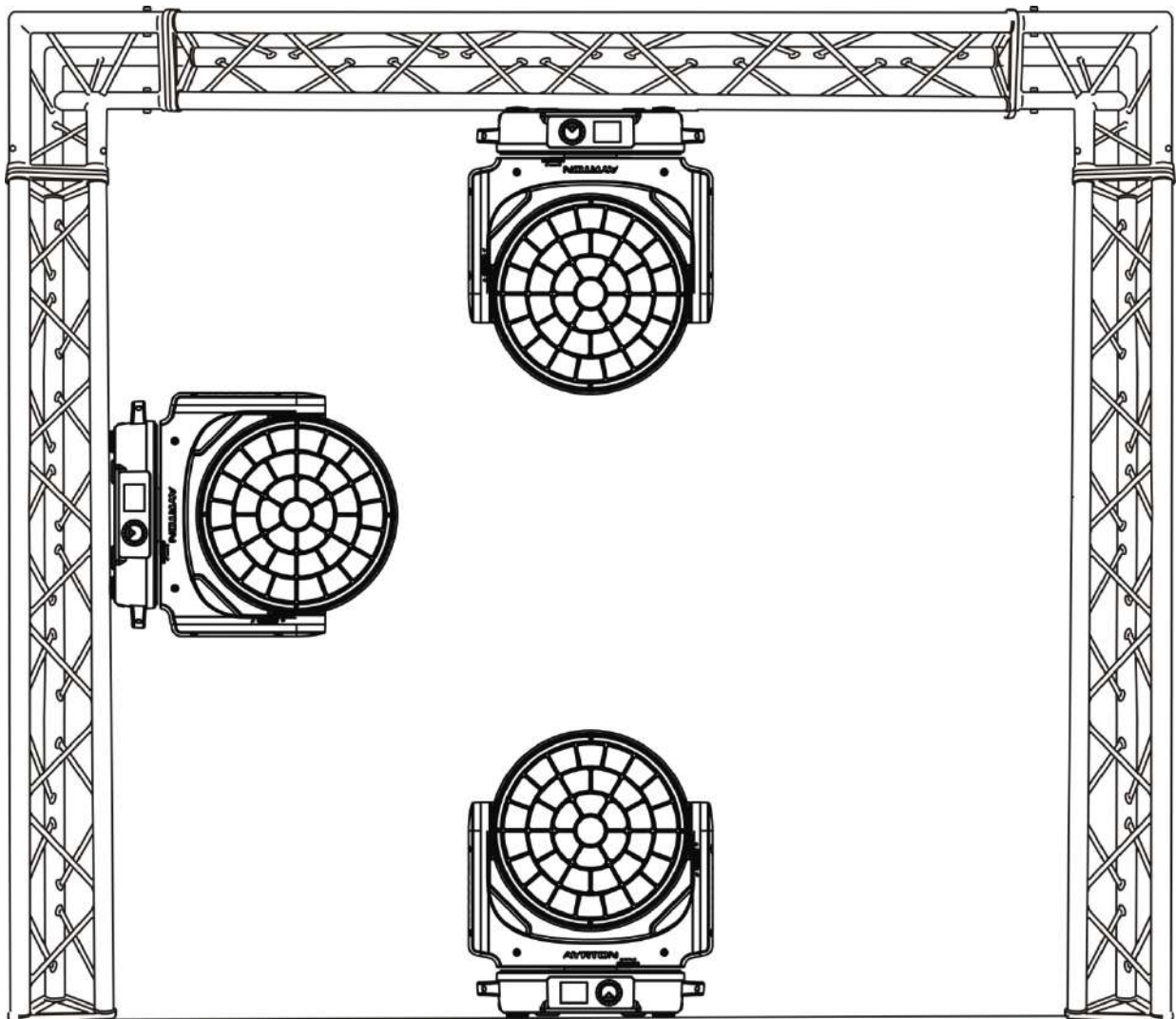

- Be sure this fixture is kept at least 0.1 m away from any flammable materials (decoration etc.).
- Always use and install the supplied safety cable as a safety measure to prevent accidental damage and/or injury in the event the clamp fails.



**Important:**

Overhead rigging requires extensive experience, including (but not limited to) calculating working load limits, specifying installation/ rigging materials, and periodic safety inspection of all installation material as well as the device. If you lack these qualifications, do not attempt the rigging of this device yourself. Improper installation/ rigging can result in serious bodily injury.

## 6. DMX-512 CONTROL CONNECTION

Connect the provided male side of the XLR cable to the female XLR output of your controller and the female side of the XLR cable to the male XLR input of the device. You can connect multiple devices together in a serial fashion. The cable needed should be two core, screened cable with XLR input and output connectors. Please refer to the diagram below.

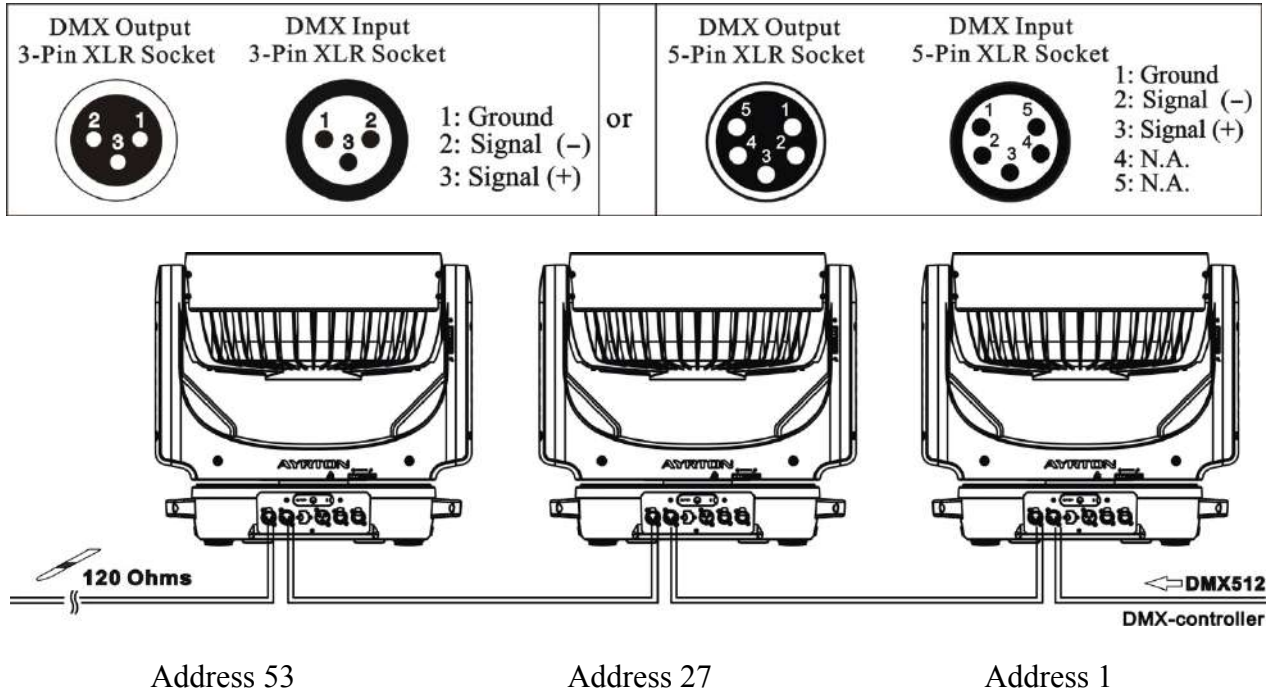

## 7. DMX-512 CONNECTION WITH DMX TERMINATOR

For installations where the DMX cable has to run over a long distance or is in an electrically noisy environment, such as in a discotheque, it is recommended to use a DMX terminator. This helps in preventing corruption of the digital control signal caused by electrical noise. The DMX terminator is an XLR plug with a 120 Ω resistor connected between pins 2 and 3, which is then plugged into the output (female) XLR socket of the last fixture in the chain. Please see illustrations below.

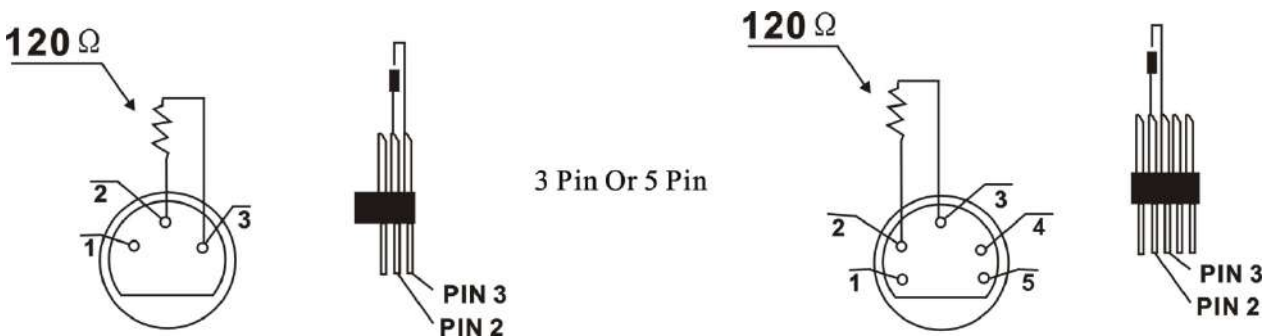

## 8. DEVICE DMX START ADDRESS SELECTION

All fixtures should be given a DMX starting address when using a DMX signal, so that the correct fixture responds to the correct control signals. This digital starting address is the channel number from which the fixture starts to “listen” to the digital control information sent out from the DMX controller. The allocation of this starting address is achieved by setting the correct address number on the display located on the base of the device.

You can set the same starting address for all fixtures or a group of fixtures, or set different addresses for each fixture individually.

If you set the same address on all devices, all the devices will start to “listen” to the same control signal from the same channel number. In other words, changing the settings of one channel will affect all the fixtures simultaneously.

If you set a different address, each unit will start to “listen” to the channel number you have set, based on the quantity of control channels of the unit. That means changing the settings of one channel will affect only the selected device.

In the case of the LED moving head, in 26 channel mode, you should set the starting address of the first unit to 1, the second unit to 27 (26 + 1), the third unit to 53 (26+ 27), and so on.

## 9. DISPLAY

The Display offers Jog Wheel features: you can set the starting address, run the pre-programmed program or reset the device.

The main menu is accessed by double clicking the Jog Wheel of Jog Wheel until the display starts flashing. Browse through the menu by turning Jog Wheel clockwise or counterclockwise.

Press the Jog Wheel for 2 seconds in order to select the desired menu or exit menu, double click the Jog Wheel for confirm. After accessing the edit mode, the unit will automatically exit to the main menu after 15 seconds from the last button press. Clockwise is positive direction while counterclockwise is opposite direction.

When the unit is powered on, if no data signal is connected after 1 minute, then the display will switch off automatically. The Display does not need external power to operate in case there is battery, hold down the Jog Wheel for 6 seconds and the Display will turn on by using the unit's battery.

PS: No response when quick press the Jog Wheel.



### CAUTION!

THE BATTERY MUST BE A LI-ION RECHARGEABLE BATTERY,  
THE SPECIFICATION IS AS FOLLOWING:

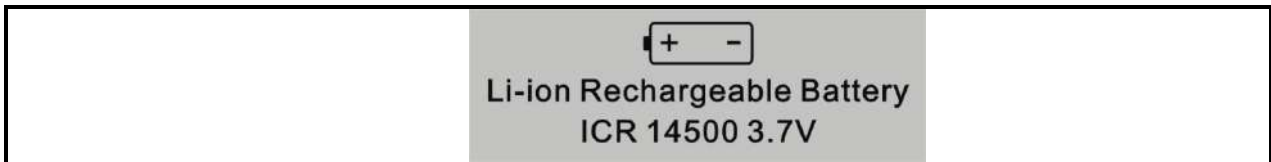

To install the battery for the first time, please make sure the unit is not connected to AC power. Install the battery in the battery holder, then remove the battery and install it back. This procedure must be done only for the first battery installation.

**Default settings shaded**

Address	Address	DMX Address: xxx Decimal Universe: xxxxx Net: xx Sub-Net: x Universe: x	DMX Address Decimal Universe Net Sub-Net Universe	
Mode	User Mode	Stand Mode Basic Mode <b>Extend Mode</b> User Mode A User Mode B User Mode C	User's mode to change channel numbers	
	Edit User ModeA/B/C	Max channel PAN :	Preset User modes A,B,C :	
Options	Status	No DMX Mode Pan Reverse Tilt Reverse Pan Degree Feedback Init PAN Init TILT Pan/Tilt Spd Hibernation DMX Output	Close/ <b>Hold</b> /Auto ON/ <b>OFF</b> ON/ <b>OFF</b> 630/ <b>540</b> ON/ <b>OFF</b> ON/ <b>OFF</b> ON/ <b>OFF</b> <b>Medium</b> /Fast/Slow <b>OFF</b> , 01M~99M ON/ <b>OFF</b>	Auto run if no DMX Pan Reverse movement Tilt Reverse movement Pan Degree Select Movement Feedback Init PAN Init TILT Movement Speed Stand by Mode DMX Output
	Service PIN	Service PIN RDM UID Set Ip Set Mask DHCP Cross Load SW USB Update Clr LED Timer <b>Clr Error Info</b>	Password=XXX Xxxxxx xxx.xxx.xxx.xxx xxx.xxx.xxx.xxx ON/ <b>OFF</b> ON/ <b>OFF</b> ON/ <b>OFF</b> ON/ <b>OFF</b>	Service Password"=050" RDM UID Set Ip Set Mask DHCP Cross Load SW USB Update Clr LED Timer <b>Clr Error Info</b>
	Fans Control	Fans Speed	<b>Auto</b> Stage Silence	Fans Speed select

			Super Silence	
		Constant Fans	ON/OFF	Constant Fans
Disp.Setting	Shutoff Time Flip Display Key Lock DispFlash	02~60m 05m ON/OFF ON/OFF ON/OFF		Display shutoff time Reverse 180 degree Key Lock DispFlash
Signal Select	DMX WDMX Art - Net sACN			DMX WDMX Art-Net sACN
Temp. C/F	Celsius Fahrenheit			Temperature switch between <input type="checkbox"/> / <input type="checkbox"/>
Initial Pos.	PAN =XXX			Initial effect position
Wireless DMX	Activate WDMX Rest WDMX			Activate WDMX Rest WDMX
Refresh Select	1.2K 2.4K 16K 25K			Refresh Select
Trigger	DMX Value Disp. Set to Slave Auto Program	PAN..... Slave1,Slave2,Slave3 Master / Alone		DMX Value Disp. Set to Slave Auto Program
ResetDefault	ON/OFF			Restore factory set.
Reset User	Address	DMX address:001-XXX :		DMX address setting
	Mode	Stand Mode Basic Mode Extend Mode User Mode A User Mode B User Mode C		User's mode to change channel numbers
	Fans Speed	Auto Stage Silence Super Silence		Fans Speed select
	Constant Fans	ON/OFF		Constant Fans
Info	Time Info.	Current Time Ttl Life Hrs Last Run Hrs LED Hours Timer PIN Clr Last Run		XXXX(Hours) XXXX(Hours) XXXX(Hours) XXXX(Hours) Password=XXX ON/OFF

	Temp. Info	XXX□/□		Temp. Info
	Fan Info.	xxxx RPM		Fan information
	Software Ver	V1.0.....		Software version
	Network	IP,Mask,Mac		Network
	Error Info.	Error Record 1 :		Error Info.
Test	Home	All Pan&Tiltr ZOOM		Reset All Reset Pan&Tilt ZOOM
	Test Channel	PAN .....		Test function
	Manual Ctrl.	PAN =XXX :		Fine adjustment of the lamp
	Calibration	-Password- PAN :		Password "050" Calbrate and adjust the effects to standard/right position
Preset	Select Prog.	Prog. Part 1 = Program 1 ~ 10 <b>Program 1</b> Prog. Part 2 = Program 1 ~ 10 <b>Program 2</b> Prog. Part 3 = Program 1 ~ 10 <b>Program 3</b>		Select programs to be run
	Edit Prog.	Program 1 : Program 10	Program Test Step 01=SCxxx Step 64=SCxxx	Testing program Program in loop Save and exit
	Edit Scenes	Edit Scene 001 ~ Edit Scene 250	Pan,Tilt,..... --Fade Time-- --Secne Time-- Input By Outside	Save and automatically return manual scenes edit
	Scenes Input	XX~XX		Scenes Input

## 9.1 Address

### 9.1.1. Set DMX Address

With this function, you can adjust the desired DMX-address via the Display.

1. Double click the Jog Wheel to access main menu.
2. The display will show "ADDRESS" .
3. Double click the Jog Wheel then display "Set DMX Address" .
4. Turn the Jog Wheel clockwise then display "DMX Address: xxx", "Decimal Universe "xxxxx", "Net: xx", "Sub-Net: x", "Universe: x" .
5. Long press 2 seconds the Jog Wheel to back to last menu – "Set DMX Address", then back to main menu by long press again.



## 9.2 Mode

### 9.2.1. User Mode

With this function, you can create user defined channel orders.

1. Double click the Jog Wheel to access main menu, turn the Jog Wheel clockwise to display “USERS MODE” .
2. Double click the Jog Wheel to edit.
3. Turn the Jog Wheel clockwise to display “User mode”, Double click the Jog Wheel to edit.
4. When in “Extend Mode”, turn the Jog Wheel to select “Basic mode”, “Stand Mode”, “User Mode A”, “User Mode B” and “User Mode C” .
5. Long press 2 seconds the Jog Wheel to back to last menu – “User Mode”, then back to main menu by long press again.

### 9.2.2. Edit User Mode

With this function, you can adjust the rest user defined channel order.

1. Double click the Jog Wheel to access “USERS MODE” menu, turn the Jog Wheel until display “Edit User” .
2. Double click the Jog Wheel to access “Edit User” menu.
3. Set up “Max Channel=xxx” and select channel value.
4. Set up “Mode B” and “Mode C” by the same way.
5. Long press 2 seconds the Jog Wheel to back to last menu – “Edit User”, then back to main menu by long press again.

## 9.3 Options

### 9.3.1. Status

#### No DMX Status

With this function, when the drive is not DMX signal, it runs automatism, close, hold and music, the default is hold.

1. Double click the Jog Wheel to access main menu.
2. Turn the Jog Wheel clockwise then display “Options” .
3. Double click the Jog Wheel to access “Options”, turn the Jog Wheel to select “Status”.
4. Double click the Jog Wheel to access “Status” menu, The display will show “No DMX Status” .
5. Double click the Jog Wheel to access “No DMX Status”, The display will show “Hold”, Turn the Jog Wheel to select “Close”, “Auto” .
6. Long press 2 seconds the Jog Wheel to back to last menu – “Status”, then back to main menu by long press again.

#### Pan Reverse

With this function you can reverse the Pan-movement.

1. Double click the Jog Wheel to access main menu.
2. Turn the Jog Wheel clockwise then display “Options” .
3. Double click the Jog Wheel to access “Options”, turn the Jog Wheel to select “Status”.
4. Double click the Jog Wheel to access “Status” menu, The display will show “Pan Reverse” .
5. Double click the Jog Wheel to access “Pan Reverse”, The display will show “OFF”, Turn the Jog Wheel to select “NO” .

6. Long press 2 seconds the Jog Wheel to back to last menu – “Status”, then back to main menu by long press again.

### **Tilt Reverse**

With this function you can reverse the Tilt-movement.

1. Double click the Jog Wheel to access main menu.
2. Turn the Jog Wheel clockwise then display “Options” .
3. Double click the Jog Wheel to access“Options”, turn the Jog Wheel to select “Status”.
4. Double click the Jog Wheel to access “Status” menu, The display will show “Tilt Reverse” .
5. Double click the Jog Wheel to access“Tilt Reverse”, The display will show “OFF”, Turn the Jog Wheel to select “NO” .
6. Long press 2 seconds the Jog Wheel to back to last menu – “Status”, then back to main menu by long press again.

### **Pan Degree**

With this function, you can select pan degree for 630 or 540.

1. Double click the Jog Wheel to access main menu.
2. Turn the Jog Wheel clockwise then display “Options” .
3. Double click the Jog Wheel to access“Options”, turn the Jog Wheel to select “Status”.
4. Double click the Jog Wheel to access “Status” menu, The display will show “Pan Degree” .
5. Double click the Jog Wheel to access “Pan Degree”, The display will show “540”, Turn the Jog Wheel to select “630” .
6. Long press 2 seconds the Jog Wheel to back to last menu – “Status”, then back to main menu by long press again.

### **Feedback**

With this function, you can feedback switch of pan movement or tilt movement.

1. Double click the Jog Wheel to access main menu.
2. Turn the Jog Wheel clockwise then display “Options” .
3. Double click the Jog Wheel to access“Options”, turn the Jog Wheel to select “Status”.
4. Double click the Jog Wheel to access“Status” menu, The display will show“Feedback”.
5. Double click the Jog Wheel to access“Feedback”, The display will show “ON”, Turn the Jog Wheel to select “OFF” .
6. Long press 2 seconds the Jog Wheel to back to last menu – “Status”, then back to main menu by long press again.

### **Init PAN**

1. Double click the Jog Wheel to access main menu.
2. Turn the Jog Wheel clockwise then display “Options” .
3. Double click the Jog Wheel to access“Options”, turn the Jog Wheel to select “Status”.
4. Double click the Jog Wheel to access“Status” menu, The display will show“Init PAN”.
5. Double click the Jog Wheel to access “Init PAN”, The display will show “ON”, Turn the Jog Wheel to select “OFF” .
6. Long press 2 seconds the Jog Wheel to back to last menu – “Status”, then back to main menu by long press again.

### **Init TILT**

1. Double click the Jog Wheel to access main menu.
2. Turn the Jog Wheel clockwise then display “Options” .
3. Double click the Jog Wheel to access“Options”, turn the Jog Wheel to select “Status”.
4. Double click the Jog Wheel to access“Status”menu, The display will show“Init TILT”.
5. Double click the Jog Wheel to access“Init TILT”, The display will show “ON”, Turn the Jog Wheel to select “OFF” .
6. Long press 2 seconds the Jog Wheel to back to last menu – “Status”, then back to main menu by long press again.

### **Pan/Tilt Spd**

With this function, you can select scan mode from 1 to 4.

1. Double click the Jog Wheel to access main menu.
2. Turn the Jog Wheel clockwise then display “Options” .
3. Double click the Jog Wheel to access“Options”, turn the Jog Wheel to select “Status”.
4. Double click the Jog Wheel to access “Status” menu, The display will show “Pan/Tilt Spd” .
5. Double click the Jog Wheel to access“Pan/Tilt Spd”, The display will show “Medium”, Turn the Jog Wheel to select “Medium”, “Fast”, “Slow” .
6. Long press 2 seconds the Jog Wheel to back to last menu – “Status”, then back to main menu by long press again.

### **Hibernation: Standby mode**

The device and step motors will be power off if the fixture stay without DMX signal for 15 mins (Factory default).And the fixture will be reset before working once it receive DMX signal again.

1. Double click the Jog Wheel to access main menu.
2. Turn the Jog Wheel clockwise then display “Options” .
3. Double click the Jog Wheel to access“Options”, turn the Jog Wheel to select “Status”.
4. Double click the Jog Wheel to access “Status” menu, The display will show “Hibernation” .
5. Double click the Jog Wheel to access “Hibernation”, The display will show “OFF”, Turn the Jog Wheel to select “01M”, “02M” . . . . “99M” .
6. Long press 2 seconds the Jog Wheel to back to last menu – “Status”, then back to main menu by long press again.

### **DMX Output**

With this function, you can select DMX Output.

1. Double click the Jog Wheel to access main menu.
2. Turn the Jog Wheel clockwise then display “Options” .
3. Double click the Jog Wheel to access“Options”, turn the Jog Wheel to select “Status”.
4. Double click the Jog Wheel to access “Status” menu, The display will show “DMX Output” .
5. Double click the Jog Wheel to access“DMX Output”, The display will show “OFF”, Turn the Jog Wheel to select “ON” .
6. Long press 2 seconds the Jog Wheel to back to last menu – “Status”, then back to main menu by long press again.

### **9.3.2. Service PIN**

#### **Password**

The Password for this function is “050” .

#### **RDM UID**

1. Double click the Jog Wheel to access main menu.
2. Turn the Jog Wheel clockwise then display “Options” .
3. Double click the Jog Wheel to access “Options”, turn the Jog Wheel to select “Service PIN” .
4. Double click the Jog Wheel to access “Service PIN” menu, The display will show “RDM UID” .
5. Double click the Jog Wheel to access “RDM UID”, The display will show “XXXXXX” .
6. Long press 2 seconds the Jog Wheel to back to last menu – “Service PIN”, then back to main menu by long press again.

#### **Set IP**

1. Double click the Jog Wheel to access main menu.
2. Turn the Jog Wheel clockwise then display “Options” .
3. Double click the Jog Wheel to access “Options”, turn the Jog Wheel to select “Service PIN” .
4. Double click the Jog Wheel to access “Service PIN” menu, The display will show “Set IP” .
5. Double click the Jog Wheel to access “Set IP”, The display will show “XXX.XXX.XXX.XXX” .
6. Long press 2 seconds the Jog Wheel to back to last menu – “Service PIN”, then back to main menu by long press again.

#### **Set Mask**

1. Double click the Jog Wheel to access main menu.
2. Turn the Jog Wheel clockwise then display “Options” .
3. Double click the Jog Wheel to access “Options”, turn the Jog Wheel to select “Service PIN” .
4. Double click the Jog Wheel to access “Service PIN” menu, The display will show “Set Mask” .
5. Double click the Jog Wheel to access “Set Mask”, The display will show “XXX.XXX.XXX.XXX” .
6. Long press 2 seconds the Jog Wheel to back to last menu – “Service PIN”, then back to main menu by long press again.

#### **DHCP**

1. Double click the Jog Wheel to access main menu.
2. Turn the Jog Wheel clockwise then display “Options” .
3. Double click the Jog Wheel to access “Options”, turn the Jog Wheel to select “Service PIN” .
4. Double click the Jog Wheel to access “Service PIN” menu, The display will show “DHCP” .
5. Double click the Jog Wheel to access “DHCP”, The display will show “ON”, Turn the Jog Wheel to select “OFF” .

6. Long press 2 seconds the Jog Wheel to back to last menu – “Service PIN”, then back to main menu by long press again.

### **Cross Load SW**

1. Double click the Jog Wheel to access main menu.
2. Turn the Jog Wheel clockwise then display “Options” .
3. Double click the Jog Wheel to access “Options”, turn the Jog Wheel to select “Service PIN” .
4. Double click the Jog Wheel to access “Service PIN” menu, The display will show “Cross Load SW” .
5. Double click the Jog Wheel to access “Cross Load SW”, The display will show “OFF”, Turn the Jog Wheel to select “ON” .
6. Long press 2 seconds the Jog Wheel to back to last menu – “Service PIN”, then back to main menu by long press again.

### **USB Update**

1. Double click the Jog Wheel to access main menu.
2. Turn the Jog Wheel clockwise then display “Options” .
3. Double click the Jog Wheel to access “Options”, turn the Jog Wheel to select “Service PIN” .
4. Double click the Jog Wheel to access “Service PIN” menu, The display will show “USB Update” .
5. Double click the Jog Wheel to access “USB Update”, The display will show “OFF”, Turn the Jog Wheel to select “ON” .
6. Long press 2 seconds the Jog Wheel to back to last menu – “Service PIN”, then back to main menu by long press again.

### **Clr LED Timer**

1. Double click the Jog Wheel to access main menu.
2. Turn the Jog Wheel clockwise then display “Options” .
3. Double click the Jog Wheel to access “Options”, turn the Jog Wheel to select “Service PIN” .
4. Double click the Jog Wheel to access “Service PIN” menu, The display will show “Clr LED Timer” .
5. Double click the Jog Wheel to access “Clr LED Timer”, The display will show “OFF”, Turn the Jog Wheel to select “ON” .
6. Long press 2 seconds the Jog Wheel to back to last menu – “Service PIN”, then back to main menu by long press again.

### **Clr Error Info**

1. Double click the Jog Wheel to access main menu.
2. Turn the Jog Wheel clockwise then display “Options” .
3. Double click the Jog Wheel to access “Options”, turn the Jog Wheel to select “Service PIN” .
4. Double click the Jog Wheel to access “Service PIN” menu, The display will show “Clr Error Info” .
5. Double click the Jog Wheel to access “Clr Error Info”, The display will show “OFF”,

Turn the Jog Wheel to select “ON” .

6. Long press 2 seconds the Jog Wheel to back to last menu –“Service PIN”, then back to main menu by long press again.

### 9.3.3. Fans Control

#### Fans Speed

With this function you can set the speed of the running fans. The selections have Auto、Stage、Silence and Super Silence.

1. Double click the Jog Wheel to access main menu.
2. Turn the Jog Wheel clockwise then display “Options” .
3. Double click the Jog Wheel to access “Options”, turn the Jog Wheel to select “Fans Control” .
4. Double click the Jog Wheel to access “Fans Control” menu, The display will show “Fans Speed” .
5. Double click the Jog Wheel to access “Fans Speed”, The display will show “Auto”, Turn the Jog Wheel to select “Stage” , “Silence” , “Super Silence” .
6. Long press 2 seconds the Jog Wheel to back to last menu –“Fans Control”, then back to main menu by long press again.

#### Constant Fans

1. Double click the Jog Wheel to access main menu.
2. Turn the Jog Wheel clockwise then display “Options” .
3. Double click the Jog Wheel to access “Options”, turn the Jog Wheel to select “Fans Control” .
4. Double click the Jog Wheel to access “Fans Control” menu, The display will show “Constant Fans” .
5. Double click the Jog Wheel to access “Constant Fans”, The display will show “OFF”, Turn the Jog Wheel to select “ON” .
6. Long press 2 seconds the Jog Wheel to back to last menu –“Fans Control”, then back to main menu by long press again.

### 9.3.4. Disp. Setting

#### Shut off Time

With this function you can shut off the LCD display after 2 to 60 minutes. The default is 5 minutes.

1. Double click the Jog Wheel to access main menu.
2. Turn the Jog Wheel clockwise then display “Options” .
3. Double click the Jog Wheel to access “Options”, turn the Jog Wheel to select “Display Setting” .
4. Double click the Jog Wheel to access “Display Setting” menu, The display will show “Shut off Time” .
5. Double click the Jog Wheel to access “Shut off Time”, The display will show “05m”, Turn the Jog Wheel to select “02~60m” .
6. Long press 2 seconds the Jog Wheel to back to last menu –“Display Setting”, then back to main menu by long press again.

#### Flip Display

With this function you can rotate the display by 180°.

1. Double click the Jog Wheel to access main menu.
2. Turn the Jog Wheel clockwise then display “Options” .
3. Double click the Jog Wheel to access “Options”, turn the Jog Wheel to select “Display Setting” .
4. Double click the Jog Wheel to access “Display Setting” menu, The display will show “Flip Display” .
5. Double click the Jog Wheel to access “Flip Display”, The display will show “OFF”, Turn the Jog Wheel to select “ON” .
6. Long press 2 seconds the Jog Wheel to back to last menu –“Display Setting”, then back to main menu by long press again.

### **Key Lock**

With this function you can activate the automatic key lock function. If this function is activated, the keys will be locked automatically after exiting the edit mode for 15 seconds. Keeping press the <MODE/ESC> key for 3 seconds if you do not need this function.

1. Double click the Jog Wheel to access main menu.
2. Turn the Jog Wheel clockwise then display “Options” .
3. Double click the Jog Wheel to access “Options”, turn the Jog Wheel to select “Display Setting” .
4. Double click the Jog Wheel to access “Display Setting” menu, The display will show “Key Lock” .
5. Double click the Jog Wheel to access “Key Lock”, The display will show “OFF”, Turn the Jog Wheel to select “ON” .
6. Long press 2 seconds the Jog Wheel to back to last menu –“Display Setting”, then back to main menu by long press again.

### **DispFlash**

With this function you can the entire display to be flipped by 180° to allow for better view when the fixture is hung from truss or a ceiling. This function is disabled as default.

1. Double click the Jog Wheel to access main menu.
2. Turn the Jog Wheel clockwise then display “Options” .
3. Double click the Jog Wheel to access “Options”, turn the Jog Wheel to select “Display Setting” .
4. Double click the Jog Wheel to access “Display Setting” menu, The display will show “DispFlash” .
5. Double click the Jog Wheel to access “DispFlash”, The display will show “OFF”, Turn the Jog Wheel to select “ON” .
6. Long press 2 seconds the Jog Wheel to back to last menu –“Display Setting”, then back to main menu by long press again.

### **9.3.5. Signal Select**

1. Double click the Jog Wheel to access main menu.
2. Turn the Jog Wheel clockwise then display “Options” .
3. Double click the Jog Wheel to access “Options”, turn the Jog Wheel to select “Signal Select” .
4. Double click the Jog Wheel to access “Signal Select”, The display will show “DMX”, Turn the Jog Wheel to select “DMX”, “WDMX”, “Art-Net”, “sACN” .

5. Long press 2 seconds the Jog Wheel to back to last menu – “Signal Select”, then back to main menu by long press again.

### **9.3.6. Temperature C/F**

With this function you can display the temperature in Celsius or Fahrenheit.

1. Double click the Jog Wheel to access main menu.
2. Turn the Jog Wheel clockwise then display “Options” .
3. Double click the Jog Wheel to access “Options”, turn the Jog Wheel to select “Temperature C/ F” .
4. Double click the Jog Wheel to access “Temperature C/ F”, The display will show “Fahrenheit”, Turn the Jog Wheel to select “Celsius” .
5. Long press 2 seconds the Jog Wheel to back to last menu – “Temperature C/ F”, then back to main menu by long press again.

### **9.3.7. Initial Pos.**

With this function you can display initial effect position.

1. Double click the Jog Wheel to access main menu.
2. Turn the Jog Wheel clockwise then display “Options” .
3. Double click the Jog Wheel to access “Options”, turn the Jog Wheel to select “Initial Pos.” .
4. Double click the Jog Wheel to access “Initial Pos.”, The display will show “PAN=XXX” .
5. Long press 2 seconds the Jog Wheel to back to last menu – “Initial Pos.”, then back to main menu by long press again.

### **9.3.8. Wireless DMX**

From factory, this projector is prepared for wireless data transmission (W-DMX) .If you wish to de-activate W-DMX control, you can select the function “De-activate WDMX” by turning the encoder. With the function “rest” , you can log out the projector from the wireless sender.

1. Double click the Jog Wheel to access main menu.
2. Turn the Jog Wheel clockwise then display “Options” .
3. Double click the Jog Wheel to access “Options”, turn the Jog Wheel to select “Wireless DMX” .
4. Double click the Jog Wheel to access “Wireless DMX”, The display will show “Activate WDMX”, Turn the Jog Wheel to select “Act&Data Out” , “Rest WDMX”.
5. Long press 2 seconds the Jog Wheel to back to last menu – “Wireless DMX”, then back to main menu by long press again.

### **9.3.9. Refresh Select**

With this function you can select the refresh.

1. Double click the Jog Wheel to access main menu.
2. Turn the Jog Wheel clockwise then display “Options” .
3. Double click the Jog Wheel to access “Options”, turn the Jog Wheel to select “Refresh Select” .
4. Double click the Jog Wheel to access “Refresh Select”, The display will show “1.2K”, Turn the Jog Wheel to select “2.4K” , “16K” , “25K” .
5. Long press 2 seconds the Jog Wheel to back to last menu – “Refresh Select”, then back to main menu by long press again.



### 9.3.10. Trigger

#### **DMX Value Disp.**

With this function you can display the DMX 512 value of each channel. The display automatically shows the channel with a value changing.

1. Double click the Jog Wheel to access main menu.
2. Turn the Jog Wheel clockwise then display “Options” .
3. Double click the Jog Wheel to access “Options”, turn the Jog Wheel to select “Trigger” .
4. Double click the Jog Wheel to access “Trigger” menu, The display will show “DMX Value Disp” .
5. Double click the Jog Wheel to access “DMX Value Disp”, The display will show “PAN=.....” .
6. Long press 2 seconds the Jog Wheel to back to last menu – “Trigger”, then back to main menu by long press again.

#### **Set to Slave**

1. Double click the Jog Wheel to access main menu.
2. Turn the Jog Wheel clockwise then display “Options” .
3. Double click the Jog Wheel to access “Options”, turn the Jog Wheel to select “Trigger” .
4. Double click the Jog Wheel to access “Trigger” menu, The display will show “Set to Slave” .
5. Double click the Jog Wheel to access “Set to Slave”, The display will show “Slave 1”、“Slave 2”、“Slave 3” .
6. Long press 2 seconds the Jog Wheel to back to last menu – “Trigger”, then back to main menu by long press again.

#### **Auto Program**

With this function, you can run the internal program. You can select the desired program under “**Select program**”. You can set the number of steps under “**Edit program**” . You can edit the individual scenes under “**Edit scenes**”. With this function, you can run the individual scenes either automatically, i.e. with the adjusted Step-Time.

1. Double click the Jog Wheel to access main menu.
2. Turn the Jog Wheel clockwise then display “Options” .
3. Double click the Jog Wheel to access “Options”, turn the Jog Wheel to select “Trigger” .
4. Double click the Jog Wheel to access “Trigger” menu, The display will show “Auto Program” .
5. Double click the Jog Wheel to access “Auto Program”, The display will show “Master” , “Alone” .
6. Long press 2 seconds the Jog Wheel to back to last menu – “Trigger”, then back to main menu by long press again.

### 9.3.11. Reset Default

With this function, you can select restore factory set for ON or OFF, the default is OFF.

1. Double click the Jog Wheel to access main menu.
2. Turn the Jog Wheel clockwise then display “Options” .

3. Double click the Jog Wheel to access “Options”, turn the Jog Wheel to select “Reset Default” .
4. Double click the Jog Wheel to access “Reset Default” menu, The display will show “OFF”, Turn the Jog Wheel to select “ON” .
5. Long press 2 seconds the Jog Wheel to back to last menu – “Reset Default”, then back to main menu by long press again.

### **9.3.12. Reset User**

#### **Address**

1. Double click the Jog Wheel to access main menu.
2. Turn the Jog Wheel clockwise then display “Options” .
3. Double click the Jog Wheel to access “Options”, turn the Jog Wheel to select “Reset User” .
4. Double click the Jog Wheel to access “Reset User” menu, The display will show “Address” .
5. Double click the Jog Wheel to access “Address”, The display will show “001~XXX”.
6. Long press 2 seconds the Jog Wheel to exit, and come back to last menu –“Reset User”, then back to main menu by pressing the Jog Wheel 2 seconds again.

#### **Mode**

1. Double click Jog Wheel to access main menu.
2. Turn the Jog Wheel clockwise then display “Options” .
3. Double click the Jog Wheel to access “Options”, turn the Jog Wheel to select “Reset User” .
4. Double click the Jog Wheel to access “Reset User” menu, The display will show “Mode” .
5. Double click the Jog Wheel to access “Mode”, The display will show “Extend Mode”. turn the Jog Wheel to select “Basic mode”, “Stand Mode”, “User Mode A”, “User Mode B” and “User Mode C” .
6. Long press 2 seconds the Jog Wheel to exit, and come back to last menu –“Reset User”, then back to main menu by pressing the Jog Wheel 2 seconds again.

#### **Fans Speed**

1. Double click Jog Wheel to access main menu.
2. Turn the Jog Wheel clockwise then display “Options” .
3. Double click the Jog Wheel to access “Options”, turn the Jog Wheel to select “Reset User” .
4. Double click the Jog Wheel to access “Reset User” menu, The display will show “Fans Speed” .
5. Double click the Jog Wheel to access “Fans Speed”, The display will show “Auto” . turn the Jog Wheel to select “Stage”, “Silence”, “Super Silence” .
6. Long press 2 seconds the Jog Wheel to exit, and come back to last menu –“Reset User”, then back to main menu by pressing the Jog Wheel 2 seconds again.

#### **Constant Fans**

1. Double click Jog Wheel to access main menu.
2. Turn the Jog Wheel clockwise then display “Options” .

3. Double click the Jog Wheel to access “Options”, turn the Jog Wheel to select “Reset User” .
4. Double click the Jog Wheel to access “Reset User” menu, The display will show “Constant Fans” .
5. Double click the Jog Wheel to access “Constant Fans”, The display will show “OFF”. turn the Jog Wheel to select “ON” .
6. Long press 2 seconds the Jog Wheel to exit, and come back to last menu – “Reset User”, then back to main menu by pressing the Jog Wheel 2 seconds again.

## **9.4 Info**

### **9.4.1. Time Info.**

#### **Current Time**

With this function, you can display the temporary running time of the device from the last power on. The display shows “XXXX”, “XXXX” stands for the number of hours. The counter is reset after turning the device off.

1. Double click the Jog Wheel to access main menu.
2. Turn the Jog Wheel clockwise then display “Info” .
3. Double click the Jog Wheel to access “Info”, turn the Jog Wheel to select “Time Info.”.
4. Double click the Jog Wheel to access “Time Info.”, The display will show “Current Time” .
5. Double click the Jog Wheel to access “Current Time”, The display will show “XXXX (Hours)” .
6. Long press 2 seconds the Jog Wheel to back to last menu – “Time Info”, then back to main menu by long press again.

#### **Ttl Life Hrs**

With this function, you can display the running time of the device. The display shows “XXXX” , “XXXX” stands for the number of hours.

1. Double click the Jog Wheel to access main menu.
2. Turn the Jog Wheel clockwise then display “Info” .
3. Double click the Jog Wheel to access “Info”, turn the Jog Wheel to select “Time Info.”.
4. Double click the Jog Wheel to access “Time Info.”, The display will show “Ttl Life Hrs” .
5. Double click the Jog Wheel to access “Ttl Life Hrs”, The display will show “XXXX (Hours)” .
6. Long press 2 seconds the Jog Wheel to back to last menu – “Time Info”, then back to main menu by long press again.

#### **Last Run Hrs**

With this function, you can display last the running time of the device. The display shows “XXXX” , “XXXX” stands for the number of hours.

1. Double click the Jog Wheel to access main menu.
2. Turn the Jog Wheel clockwise then display “Info” .
3. Double click the Jog Wheel to access “Info”, turn the Jog Wheel to select “Time Info.”.
4. Double click the Jog Wheel to access “Time Info.”, The display will show “Last Run Hrs” .

5. Double click the Jog Wheel to access “Last Run Hrs”, The display will show “XXXX (Hours)” .
6. Long press 2 seconds the Jog Wheel to back to last menu – “Time Info”, then back to main menu by long press again.

### **LED Hours**

1. Double click the Jog Wheel to access main menu.
2. Turn the Jog Wheel clockwise then display “Info” .
3. Double click the Jog Wheel to access“Info”, turn the Jog Wheel to select “Time Info.”.
4. Double click the Jog Wheel to access “Time Info.”, The display will show “LED Hours” .
5. Double click the Jog Wheel to access “Last Run Hrs”, The display will show “XXXX (Hours)” .
6. Long press 2 seconds the Jog Wheel to back to last menu – “Time Info”, then back to main menu by long press again.

### **Timer PIN**

With this function, you can display the timer password.

1. Double click the Jog Wheel to access main menu.
2. Turn the Jog Wheel clockwise then display “Info” .
3. Double click the Jog Wheel to access“Info”, turn the Jog Wheel to select “Time Info.”.
4. Double click the Jog Wheel to access “Time Info.”, The display will show “Timer PIN” .
5. Double click the Jog Wheel to access “Timer PIN”, The display will show “Password=038” .
6. Long press 2 seconds the Jog Wheel to back to last menu – “Time Info”, then back to main menu by long press again.

### **Clr Last Run**

With this function, you can clear last run time of the fixture.The display shows “ON” or “OFF”, Press “Enter” to confirm.

1. Double click the Jog Wheel to access main menu.
2. Turn the Jog Wheel clockwise then display “Info” .
3. Double click the Jog Wheel to access“Info”, turn the Jog Wheel to select “Time Info.”.
4. Double click the Jog Wheel to access“Time Info.”, The display will show “Clear Last Run” .
5. Double click the Jog Wheel to access“Clear Last Run”, The display will show “OFF”, turn the Jog Wheel to select “ON” .
6. Long press 2 seconds the Jog Wheel to back to last menu – “Time Info”, then back to main menu by long press again.

### **9.4.2. Temp.Info**

With this function you can display the temperature on the display board of the base (near CMY-filter) in Celsius.

1. Double click the Jog Wheel to access main menu.
2. Turn the Jog Wheel clockwise then display “Info” .
3. Double click the Jog Wheel to access“Info”, turn the Jog Wheel to select “Temp Info”.
4. Double click the Jog Wheel to access “Temp Info”, The display will show “Head

Temp.” .

5. Double click the Jog Wheel to access “Head Temp.”, The display will show “xxx °C/ °F” .
6. Long press 2 seconds the Jog Wheel to back to last menu – “Temp Info”, then back to main menu by long press again.

#### **9.4.3. Fan Info.**

With this function, you can display the software version of the device.

1. Double click the Jog Wheel to access main menu.
2. Turn the Jog Wheel clockwise then display “Info” .
3. Double click the Jog Wheel to access “Info”, turn the Jog Wheel to select “Fan Info.”.
4. Double click the Jog Wheel to access “Fan Info.”, The display will show “xxxx RPM”.
5. Long press 2 seconds the Jog Wheel to back to last menu – “Fan Info.”, then back to main menu by long press again.

#### **9.4.4. Software Ver**

With this function, you can display the software version of the device.

1. Double click the Jog Wheel to access main menu.
2. Turn the Jog Wheel clockwise then display “Info” .
3. Double click the Jog Wheel to access “Info”, turn the Jog Wheel to select “Software Ver” .
4. Double click the Jog Wheel to access “Software Ver”, The display will show “V1.0.....” .
5. Long press 2 seconds the Jog Wheel to back to last menu – “Software Ver”, then back to main menu by long press again.

#### **9.4.5. Network**

1. Double click the Jog Wheel to access main menu.
2. Turn the Jog Wheel clockwise then display “Info” .
3. Double click the Jog Wheel to access “Info”, turn the Jog Wheel to select “Network”.
4. Double click the Jog Wheel to access “Network”, The display will show “IP” , Turn the Jog Wheel to select “Mask”, “Mac” .
5. Long press 2 seconds the Jog Wheel to back to last menu – “Network”, then back to main menu by long press again.

#### **9.4.6. Error Info.**

1. Double click the Jog Wheel to access main menu.
2. Turn the Jog Wheel clockwise then display “Info” .
3. Double click the Jog Wheel to access “Info”, turn the Jog Wheel to select “Error Info.”.
4. Double click the Jog Wheel to access “Error Info.”, The display will show “Error Record 1” , “.....” .
5. Long press 2 seconds the Jog Wheel to back to last menu – “Network”, then back to main menu by long press again.

## **9.5 Test**

### **9.5.1. Home**

With this function you can reset the device via the Control Board. You can select the

different reset functions by turning the encoder.

1. Double click the Jog Wheel to access main menu.
2. Turn the Jog Wheel clockwise then display “Test” .
3. Double click the Jog Wheel to access “Test”, turn the Jog Wheel to select “Home” .
4. Double click the Jog Wheel to access “Home”, The display will show “All”, Turn the Jog Wheel to select “All”, “Pan&Tilt”, “Color”, “Gobo”, “Other” .
5. Long press 2 seconds the Jog Wheel to back to last menu – “Test”, then back to main menu by long press again.

### **9.5.2. Test Channel**

With this function you can test each channel’s function to ensure correct operation.

1. Double click the Jog Wheel to access main menu.
2. Turn the Jog Wheel clockwise then display “Test” .
3. Double click the Jog Wheel to access “Test”, turn the Jog Wheel to select “Test Channel” .
4. Double click the Jog Wheel to access “Test Channel”, The display will show “Pan”, Turn the Jog Wheel to select other channel.
5. Long press 2 seconds the Jog Wheel to back to last menu – “Test”, then back to main menu by long press again.

### **9.5.3. Manual Control**

When set to Manual Mode, fixture will be back to factory settings.If want to adjust brightness, can adjust by shutter and dimming channel, channel value is 0-255.Other functions can be set according to user's real need.

1. Double click the Jog Wheel to access main menu.
2. Turn the Jog Wheel clockwise then display “Test” .
3. Double click the Jog Wheel to access “Test”, turn the Jog Wheel to select “Manual control” .
4. Double click the Jog Wheel to access “Manual control”, The display will show “PAN=XXX” .
5. Long press 2 seconds the Jog Wheel to back to last menu – “Test”, then back to main menu by long press again.

### **9.5.4. Calibration**

With this function, you can calibrate and adjust the effect wheels to their correct positions.The password of calibrate values is 050.

1. Double click the Jog Wheel to access main menu.
2. Turn the Jog Wheel clockwise then display “Test” .
3. Double click the Jog Wheel to access “Test”, turn the Jog Wheel to select “Calibration” .
4. Double click the Jog Wheel to access “Calibration”, The display will show “Password=050” .
5. Long press 2 seconds the Jog Wheel to back to last menu – “Test”, then back to main menu by long press again.

## **9.6 Preset**

1. Double click the Jog Wheel to access main menu.

2. Turn the Jog Wheel clockwise then display “Preset” .
3. Double click the Jog Wheel to access “Preset”, turn the Jog Wheel to select “Select prog.”, “Edit prog.”, “Edit Scenes”, “Scenes Input” .
4. Long press 2 seconds the Jog Wheel to back to last menu – “Preset”, then back to main menu by long press again.

Run the auto program: A master fixture can output to three different program signals to the slave fixture to operate. It means the host will send cyclically in the following orders (The host will keep operating the program of Part 1) Then the slave fixture will make the selectively receiving according to its own set.

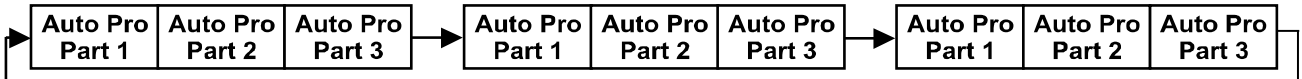

1. If the slave fixture chooses Run For Slave 1 from the menu of 1-3, then it will receive the part 1’s automatic program from link, in the same way, when the slave fixture chooses Run For Slave 2, then it will receive the part 2’s automatic program from link.
2. Enter the menu of 1-3 Function Mode---Set To Slave, Here to set machine operate which part of the program during the host-slave connection
3. Enter the menu of 1-4, 1-5 Function Mode---Set To Master
4. Enter the menu of 8-1 Edit Program---Auto Program Part1. The host outputs three groups driven program---Part1, Part2, Part3 (Part1 program runs the same effect as the host)
5. Enter the menu of 8-2 Edit Program---Edit Program. Edit the program’s connection, connect the scene in order
6. The editor of the scene, there are as many as 250 scenario editors, and every scene can have a program connection of 10.

**Note:**

Part 2, Part 3 repeat in accordance with the Part1’s repeat. For example: When Part 1 uses Program 2, Part 2 uses Program 4, Part 3 uses Program 6, Assume: Program 2 includes scene of 10, 11, 12, 13; Program 4 includes scene of 8, 9, 10; Program 6 includes scene of 12, 13, 14, 15; Then it will run as below.

Example:

**Part 1:**

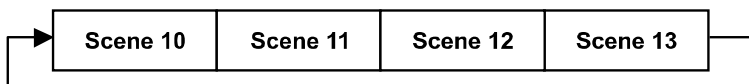

**Part 2:**

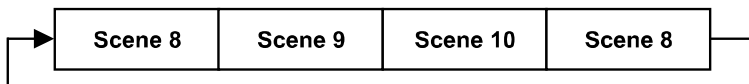

**Part 3:**

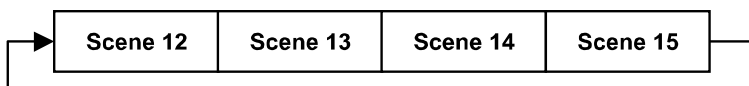

## 10. DMX PROTOCOL

DMX channel's functions and their values (54DMX channels):				
X9 Mode/Channel			Value	Function
Was h	W + Macro	W + M + Ring		
1	1	1		<b><u>PAN Movement 8bit:</u></b>
			0-255	Pan Movement
2	2	2		<b><u>Pan Fine 16bit:</u></b>
			0-255	Fine control of Pan movement
3	3	3		<b><u>TILT Movement 8bit :</u></b>
			0-255	Tilt Movement
4	4	4		<b><u>Tilt Fine 16bit:</u></b>
			0-255	Fine control of Tilt movement
5	5	5		<b><u>Speed Pan/Tilt movement:</u></b>
			0-225	max to min speed
			226-235	blackout by movement
			236-255	no function
6	6	6		<b><u>Reserved channel:</u></b>
			0-255	Reserved
7	7	7		<b><u>Reserved channel:</u></b>
			0-255	Reserved
8	8	8		<b><u>Red LED -all arrays / Background color when Chase ON :</u></b>
			0-255	Red ( 0-Black , 255-100% Red )
9	9	9		<b><u>Red fine LED -all arrays / Background color when Chase ON :</u></b>
			0-255	Red fine ( 0-Black , 255-100% Red )
10	10	10		<b><u>Green LED-all arrays / Background color when Chase ON :</u></b>
			0-255	Green ( 0-Black , 255-100% Green )
11	11	11		<b><u>Green fine LED-all arrays / Background color when Chase ON:</u></b>
			0-255	Green fine ( 0-Black , 255-100% Green )
12	12	12		<b><u>Blue LED -all arrays / Background color when Chase ON:</u></b>
			0-255	Blue ( 0-Black , 255-100% Blue )
13	13	13		<b><u>Blue fine LED -all arrays / Background color when Chase ON:</u></b>
			0-255	Blue fine ( 0-Black , 255-100% Blue )



14	14	14		<b><u>White LED -all arrays / Background color when Chase ON:</u></b>
			0-255	White ( 0-Black , 255-100% White )
15	15	15		<b><u>White fine LED -all arrays / Background color when Chase ON:</u></b>
			0-255	White fine ( 0-Black , 255-100% White )
16	16	16		<b><u>Shutter, strobe:</u></b>
			0-31	Led trun off
			32-63	Led turn on
			64-95	Strobe effect slow to fast
			96-127	Led turn on
			128-159	Pulse-effect in sequences
			160-191	Led turn on
			192-223	Random strobe effect slow to fast
224-255	Led turn on			
17	17	17		<b><u>Dimmer intensity:</u></b>
			0-255	Intensity 0 to 100%
18	18	18		<b><u>Dimmer fine intensity:</u></b>
			0-255	Intensity fine 0 to 100%
19	19	19		<b><u>Linear CTO from 8000 to 2700K:</u></b>
			0-21	No function
			22-42	8000K
			43-63	7500K
			64-84	7000K
			85-105	6500K
			106-126	6000K
			127-147	5500K
			148-168	5000K
			169-189	4500K
			190-210	4000K
			211-231	3500K
232-255	2700K			
20	20	20		<b><u>Color preset:</u></b>
			0-255	See Appendix
21	21	21		<b><u>Color Preset / RGBW cross fade:</u></b>
			0	Output controled by RGBW values
			1-254	Cross fade between RGBW settings and Color

				preset channel
			255	Output controlled by color preset values
22	22	22		<b><u>Between Color Preset cross fade:</u></b>
			0-4	no fade
			4-255	Cross fade between 2 color presets from 100ms to 5sec
23	23	23		<b><u>Zoom :</u></b>
			0-255	Zoom adjustment
24	24	24		<b><u>Zoom Fine :</u></b>
			0-255	Fine control for Zoom adjustment
25	25	25		<b><u>Reserved channel:</u></b>
			0-255	Reserved
26	26	26		<b><u>Reset, internal programs:</u></b>
			0-4	unused
			5-9	Display Off
			10-14	Display On
			15-19	Display Invert Off
			20-24	Display Invert On
			25-26	Auto fan control mode
			27-28	Stage fan control mode
			29-30	Silence fan control mode
			31-32	Super Silence fan control mode
			33-34	Constant Fans Off
			35-36	Constant Fans On
			37-44	unused
			45-49	Square Law
			50-54	Linear
			55-57	1.2K
			58-60	2.4K
			61-63	16K
			64-69	25K
			70-71	Tungsten lamp simulation 500W
72-73	Tungsten lamp simulation 1000W			
74-75	Tungsten lamp simulation 2500W			
76-77	Tungsten lamp simulation 5000W			
78-79	Tungsten lamp simulation off			

			80-84	All motor reset
			85-87	P/T motor reset
			88-90	Zoom motor reset
			90-255	Reserved
				<b><u>Main LED Chase Patterns:</u></b>
			0--9	Chase OFF
			10-14	Chase 1
			15-19	Chase 2
			20-24	Chase 3
			25-29	Chase 4
			30-34	Chase 5
			35-39	Chase 6
			40-44	Chase 7
			45-49	Chase 8
			50-54	Chase 9
	27	27	55-59	Chase 10
			60-64	Chase 11
			65-69	Chase 12
			70-74	Chase 13
			75-79	Chase 14
			80-84	Chase 15
			85-89	Chase 16
			90-94	Chase 17
			95-99	Chase 18
			100-104	Chase 19
			105-109	Chase 20
			110-255	Reserved
				<b><u>Main LED Chase Speed:</u></b>
			0-125	Fast to Slow Backward
	28	28	126-130	Stop(Speed=0)
			131-255	Slow to Fast Forward
				<b><u>Main LED Chase Fade:</u></b>
	29	29	0-255	Fade Chase
				<b><u>Main LED Chase Size:</u></b>
	30	30	0-255	chase category
				<b><u>Red Chase color:</u></b>
	31	31		

			0-255	Red ( 0-Black , 255-100% Red )
	32	32		<b><u>Green Chase color:</u></b>
			0-255	Green ( 0-Black , 255-100% Green)
	33	33		<b><u>Blue Chase color:</u></b>
			0-255	Blue ( 0-Black , 255-100% Blue )
	34	34		<b><u>White Chase color:</u></b>
			0-255	Blue ( 0-Black , 255-100% White )
	35	35		<b><u>Dimmer Chase:</u></b>
			0-255	Intensity ( 0-Black , 255-100% )
	36	36		<b><u>Dimmer background Chase: inverted disabled when chase OFF</u></b>
			0-255	Intensity ( 0-100% , 255-0% )
	37	37		<b><u>Chase,stroke:</u></b>
			0-31	Led trun off
			32-63	Led turn on
			64-95	Strobe effect slow to fast
			96-127	Led turn on
			128-159	Pulse-effect in sequences
			160-191	Led turn on
			192-223	Random strobe effect slow to fast
			224-255	Led turn on
		38		<b><u>Cross fade to PIXEL mode:</u></b>
			0-255	from RGBW control to PIXEL control
		39		<b><u>Red LED -array 1 :</u></b>
			0-255	Red ( 0-Black , 255-100% Red )
		40		<b><u>Green LED-array 1 :</u></b>
			0-255	Green ( 0-Black , 255-100% Green )
		41		<b><u>Blue LED -array 1 :</u></b>
			0-255	Blue ( 0-Black , 255-100% Blue )
		42		<b><u>White LED -array 1 :</u></b>
			0-255	White ( 0-Black , 255-100% White )
		43		<b><u>Red LED -array 2 :</u></b>
			0-255	Red ( 0-Black , 255-100% Red )
		44		<b><u>Green LED-array 2 :</u></b>
			0-255	Green ( 0-Black , 255-100% Green )
		45		<b><u>Blue LED -array 2 :</u></b>

			0-255	Blue ( 0-Black , 255-100% Blue )
		46		<b>White LED -array 2 :</b>
			0-255	White ( 0-Black , 255-100% White )
		47		<b>Red LED -array 3 :</b>
			0-255	Red ( 0-Black , 255-100% Red )
		48		<b>Green LED-array 3 :</b>
			0-255	Green ( 0-Black , 255-100% Green )
		49		<b>Blue LED -array 3 :</b>
			0-255	Blue ( 0-Black , 255-100% Blue )
		50		<b>White LED -array 3:</b>
			0-255	White ( 0-Black , 255-100% White )
		51		<b>Red LED -array 4 :</b>
			0-255	Red ( 0-Black , 255-100% Red )
		52		<b>Green LED-array 4 :</b>
			0-255	Green ( 0-Black , 255-100% Green )
		53		<b>Blue LED -array 4 :</b>
			0-255	Blue ( 0-Black , 255-100% Blue )
		54		<b>White LED -array 4:</b>
			0-255	White ( 0-Black , 255-100% White )

## 11. ERROR MESSAGES

When you turn on the device, it will first perform a reset. The display may show “Err channel is XX” should there be problems with one or more functions. “XX” stands for channel 1, 2, 3, 4, 5, 6 etc whose sensor has encountered a problem. For example, when the display shows “Err channel is Pan movement”, it means there is an error on channel 1. If there are errors on channel 1, channel 3, channel 12 at the same time, you may see the error message, “Err channel is Pan movement”, “Err channel is Tilt movement” “Err channel is Shutter”, flash twice, and then the device will generate a second reset. If the error messages persist after performing a reset more than twice, the channels which have errors may not work properly however, all other functions can work as usual. Please contact your dealer or manufacturer for service. Self repair is not allowed.

### **PAN- movement Er**

(PAN- yoke movement error) This message will appear after the reset of the fixture if the yoke’s magnetic-indexing circuit malfunction (Optical Sensor or Magnetic Sensor fails) or the stepper motor is defective (or its driving IC on the main PCB). The PAN- movement is not located in the default position after the reset.

### **TILT- movement Er**

(TILT- head movement error) This message will appear after the reset of the fixture if the head’s magnetic-indexing circuit malfunctions ((Optical Sensor or Magnetic Sensor fails)) or the stepper motor is defective (or its driving IC on the main PCB). The TILT- movement is not located in the default position after the reset.

### **Zoom wheel Er**

(Zoom wheel error) This message will appear after the reset of the fixture if the head’s magnetic-indexing circuit malfunctions (Optical Sensor or Magnetic Sensor fails) or the stepper motor is defective (or its driving IC on the main PCB). The Zoom - movement is not located in the default position after the reset.

## 12. CLEANING AND MAINTENANCE

The following points have to be considered during inspection:

- 1) All screws for installing the devices or parts of the device have to be tightly connected and must not be corroded.
  - 2) There must not be any deformations to the housing, lenses, rigging and installation points (ceiling, suspension, trussing).
  - 3) Motorized parts must not show any signs of wear and must move smoothly without issue.
  - 4) The power supply cables must not show any damage, material fatigue or sediment.
- Further instructions depending on the installation location and usage have to be adhered to by a qualified installer and any safety concerns have to be removed.



### CAUTION!

Disconnect from mains before starting maintenance operation.

In order to ensure the device remains in good condition and does not fail prematurely, we suggest regular maintenance.

- 1) Clean the inside and outside lens each week to avoid loss of output due to accumulation of dust/ dirt on the lens.
- 2) Clean the fans each week to ensure maximum airflow and efficient thermal cooling. This will ensure the light source is operated in the best possible condition.
- 3) A detailed electrical check by an approved electrician every quarter to make sure that the circuit contacts are in good condition. This will prevent poor circuit contacts and the resultant overheating.

We recommend frequent cleaning of the device. Please use a moist, lint-free cloth. Never use alcohol or solvents.

Please refer to the instructions under “Installation instructions” .

Should you need any spare parts, please order genuine parts from your local dealer.

**Remark:** Errors and omissions for all information given in this manual are excepted. All information is subject to change without prior notice.

