

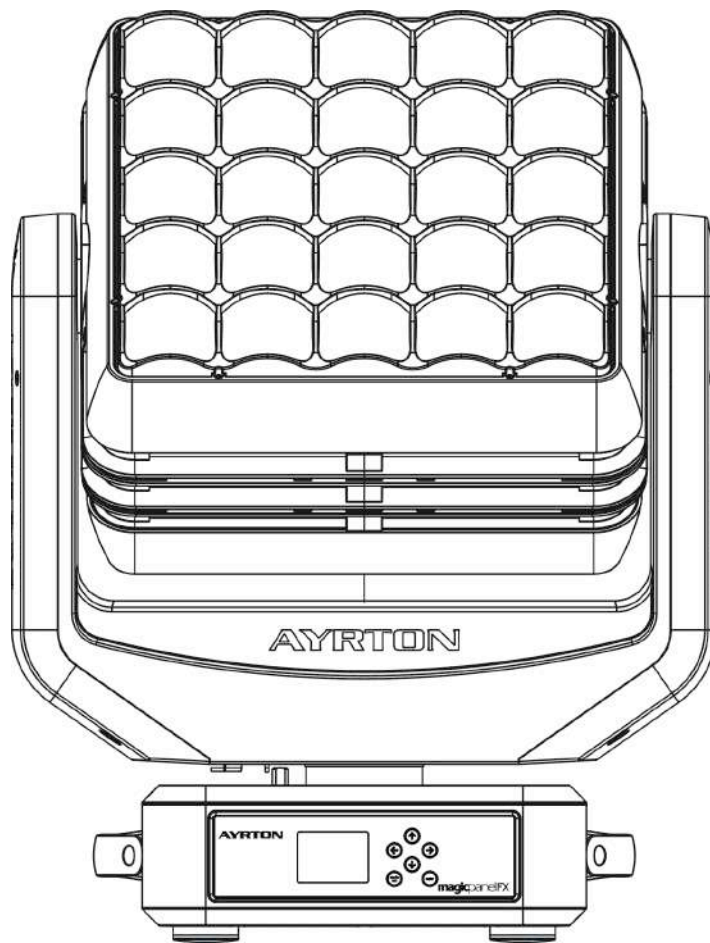

Manuel d'utilisation



magicpanelFX

KEEP THIS MANUAL FOR FUTURE NEEDS





Contents

| | |
|--|------------------------------------|
| 1. FEATURES..... | 2 |
| 2. FIXTURE OVERVIEW..... | 3 |
| 3. SAFETY INSTRUCTIONS..... | 3 |
| 3.1) Important safety warns..... | 3 |
| 3.2) General Guidelines..... | 4 |
| 4. INSTALLATION INSTRUCTIONS..... | 5 |
| 4.1) Mounting the device..... | 5 |
| 5. DMX-512 control connection..... | 8 |
| 6. DMX-512 connection with DMX terminator..... | 9 |
| 7. Projector DMX start address selection..... | 9 |
| 8. Operating instructions of the internal DMX wireless system..... | 10 |
| 9. Control Board..... | 11 |
| 9.1 Address..... | Erreur ! Signet non défini. |
| 9.1.1 Set Main Addr..... | Erreur ! Signet non défini. |
| 9.1.2 Set LED Addr..... | Erreur ! Signet non défini. |
| 9.1.3 Main Universe..... | Erreur ! Signet non défini. |
| 9.1.4 Led Universe..... | Erreur ! Signet non défini. |
| 9.2 Users mode..... | Erreur ! Signet non défini. |
| 9.2.1 User mode..... | Erreur ! Signet non défini. |
| 9.2.2 Edit User..... | Erreur ! Signet non défini. |
| 9.3 Options..... | Erreur ! Signet non défini. |
| 9.3.1 Status..... | Erreur ! Signet non défini. |
| 9.3.2 Service PIN..... | Erreur ! Signet non défini. |
| 9.3.3 Fans Control..... | Erreur ! Signet non défini. |
| 9.3.4 Disp. Setting..... | Erreur ! Signet non défini. |
| 9.3.5 Signal Select..... | Erreur ! Signet non défini. |
| 9.3.6 Temp. C/F..... | Erreur ! Signet non défini. |
| 9.3.7 Initial Pos..... | Erreur ! Signet non défini. |
| 9.3.8 Trigger..... | Erreur ! Signet non défini. |
| 9.3.9 ResetDefault..... | Erreur ! Signet non défini. |
| 9.4 Info..... | Erreur ! Signet non défini. |
| 9.4.1 Time info..... | Erreur ! Signet non défini. |
| 9.4.2 Temp. Info..... | Erreur ! Signet non défini. |
| 9.4.3 Software Ver..... | Erreur ! Signet non défini. |
| 9.4.4 Network..... | Erreur ! Signet non défini. |
| 9.5 Test..... | Erreur ! Signet non défini. |
| 9.5.1 Home..... | Erreur ! Signet non défini. |
| 9.5.2 Test Channel..... | Erreur ! Signet non défini. |
| 9.5.3 Manual Ctrl..... | Erreur ! Signet non défini. |
| 9.5.4 Calibration..... | Erreur ! Signet non défini. |
| 9.6 Preset..... | Erreur ! Signet non défini. |
| 9.6.1 Select Prog..... | Erreur ! Signet non défini. |
| 9.6.2 Edit Prog..... | Erreur ! Signet non défini. |
| 9.6.3 Edit Scenes..... | Erreur ! Signet non défini. |
| 9.6.4 Scenes Input..... | Erreur ! Signet non défini. |
| 10. INSTRUCTIONS ON USE:..... | 22 |
| 11. ERROR MESSAGE..... | 29 |
| 12. CLEANING AND MAINTENANCE..... | 30 |
| 13. TECHNICAL SPECIFICATIONS..... | 30 |

Thank you for your patronage. We are confident that our excellent products and service can satisfy you. For your own safety, please read this user manual carefully before installing the device.

In order to install, operate, and maintain the lighting safely and correctly. We suggest that the installation and operation should be done by the verified technician and follow the instructions strictly.

| | |
|---|---|
|  | CAUTION! Keep this device away from rain and moisture ! |
|  | CAUTION! Unplug mains lead before opening the housing. |

Every person involved with the installation, operation and maintenance of this device has to:
-be qualified
-follow carefully the instructions of this manual

INTRODUCTION:

Thank you for having chosen this professional moving head.
You will see you have acquired a powerful and versatile device.

Unpack the device. Inside the box you should find:

1. One safety rope
2. Manual
3. Two omega clamps

Please check carefully that there is no damage caused by transportation. Should there be any, consult your dealer and don't install this device.

1. FEATURES

- Extremely Long Life:50,000 Hr and low power consumption
- 3 DMX channel mode: 18/19/22 channels
- Pan/tilt movement: 8 bit and 16 bit resolution
 - For smooth and precise resolution
 - Pan: 540°/630° optional, Tilt: 540°/270°movement
 - High speed of pan/tilt movement, speed of pan/tilt movement is adjustable
 - Scan position memory, auto reposition after unexpected movement
- Control board with full color LCD graphic display and touch-keyboard
- Display: Can be changed 180° reverse to fit for different installation position.
- Rechargeable Back up Battery for Display
 - Software-upload by optional accessory via DMX line

2. FIXTURE OVERVIEW

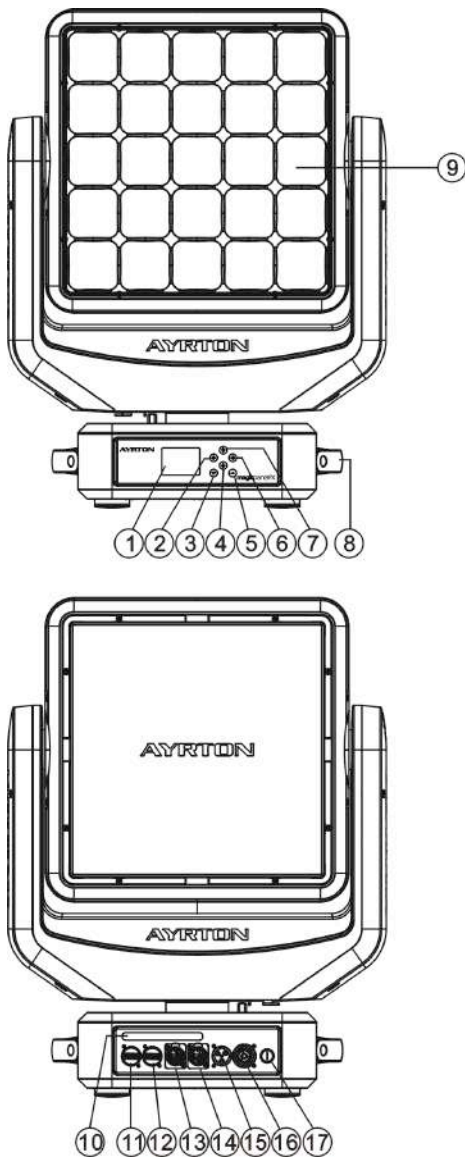

- 1) Display
- 2) Left-button
- 3) Mode/Esc-button
- 4) Down-button
- 5) ENTER-button
- 6) Right-button
- 7) Up-button
- 8) Handle
- 9) Lens
- 10) Antenna – Wireless DMX
- 11) DMX out
- 12) DMX in
- 13) RJ45 out
- 14) RJ45 in
- 15) Power in
- 16) Power out
- 17) Fuse

3. SAFETY INSTRUCTIONS

3.1) Important safety warns

| | |
|---|---|
|  | <p>CAUTION! Be careful with your operations. With a dangerous voltage you can Suffer a dangerous electric shock when touching wires!</p> |
|---|---|

This device has left the factory in perfect condition. In order to maintain this condition and to ensure a safe operation, it is absolutely necessary for the user to follow the safety instructions and warning notes written in this user manual.

Important:
 **Damages caused by the disregard of this user manual are not subject to warranty. The dealer will not accept liability for any resulting defects or problems.**

If the device has been exposed to temperature changes due to environmental changes, do not switch it on immediately. The arising condensation could damage the device. Leave the device

switched off until it has reached room temperature.

This device falls under protection-class I. Therefore it is essential that the device be earthed.

If protection screen, lens or ultraviolet screen in the fixture is apparently damaged or is damaged to exceed their own effective degree, such as cracked and gashed, it must be replaced.

The electric connection must carry out by qualified person.

Make sure that the available voltage is not higher than stated at the end of this manual.



Make sure the power cord is never crimped or damaged by sharp edges. If this would be the case, replacement of the cable must be done by an authorized dealer.

Always disconnect from the mains, when the device is not in use or before cleaning it. Only handle the power cord by the plug. Never pull out the plug by tugging the power cord.

During initial start-up some smoke or smell may arise. This is a normal process and does not necessarily mean that the device is defective, it should decrease gradually.

Please don't project the beam onto combustible substances.

If the external flexible cable or cord of this luminaire is damaged, it shall be exclusively replaced by the manufacturer or his service agent or a similar qualified person in order to avoid a hazard.

| | |
|---|--|
|  | <p>CAUTION!</p> <p>Never touch the device during operation! The housing may heat up</p> |
|  | <p>CAUTION!</p> <p>Never look directly into the light source, as sensitive persons may suffer an epileptic shock.</p> |

Please be aware that damages caused by manual modifications to the device are not subject to warranty. Keep away from children and non-professionals.

3.2) General Guidelines

This device is a lighting effect for professional use on stages, in discotheques, theatres, etc., the device was designed for indoor use only.

This fixture is only allowed to be operated with the max alternating current which stated in the technical specifications in the last page of this manual.

Lighting effects are not designed for permanent operation. Consistent operation breaks may ensure that the device will serve you for a long time without defects.

Do not shake the device. Avoid brute force when installing or operating the device.

While choosing the installation-spot, please make sure that the device is not exposed to extreme heat, moisture or dust. Please don't project the beam onto combustible substances. The minimum distance between light-output from the projector and the illuminated surface must be more than 0.5 meter.

If you use the quick lock cam in hanging up the fixture, please make sure the quick lock fasteners turned in the quick lock holes correctly.

Operate the device only after having familiarized with its functions. Do not permit operation by persons not qualified for operating the device. Most damages are the result of unprofessional operation.

Please use the original packaging if the device is to be transported.

For safety reasons, please be aware that all modifications on the device are forbidden.

If this device will be operated in any way different to the one described in this manual, the product may suffer damages and the guarantee becomes void. Furthermore, any other operation may lead to short-circuit, burns, electric shock, lamp explosion, crash, etc.

4. INSTALLATION INSTRUCTIONS

| | |
|---|--|
|  | <p style="text-align: center;">CAUTION!</p> <p style="text-align: center;">Do not operate this device with open cover</p> |
|---|--|

4.1) Mounting the device

| | |
|---|---|
|  | <p style="text-align: center;">CAUTION!</p> <p>Please consider the GB7000.1-2007,GB7000.217-2008 and the other respective national norms during the installation. The installation must only be carried out by a qualified person.</p> |
|---|---|

The applicable temperature for the lighting is between -10°C to 45°C. Do not use the lighting under or above the temperature.

The installation of the effect has to be built and constructed in a way that it can hold 10 times the weight for 1 hour without any harming deformation.

The installation must always be secured with a secondary safety attachment, e.g. an appropriate safety rope.

Never stand directly below the device when mounting, removing or servicing the fixture.

The operator has to make sure the safety relating and machine technical installations are approved by an expert before taking the device into operation for the first time.

These installations have to be approved by a skilled person once a year.

Overhead mounting requires extensive experience, including amongst others calculating working load limits, installation material being used, and periodic safety inspection of all installation material and the device. If you lack these qualifications, do not attempt the installation yourself. Improper installation can result in bodily injury.

| | |
|---|--|
|  | <p style="text-align: center;">CAUTION!</p> <p style="text-align: center;">The electric connection must only be carried out by a qualified electrician.</p> |
|---|--|

Before mounting make sure that the installation area can hold a minimum point load of 10 times the device's weight.

Connect the fixture to the mains with the power plug.

Installation via the Omega holders

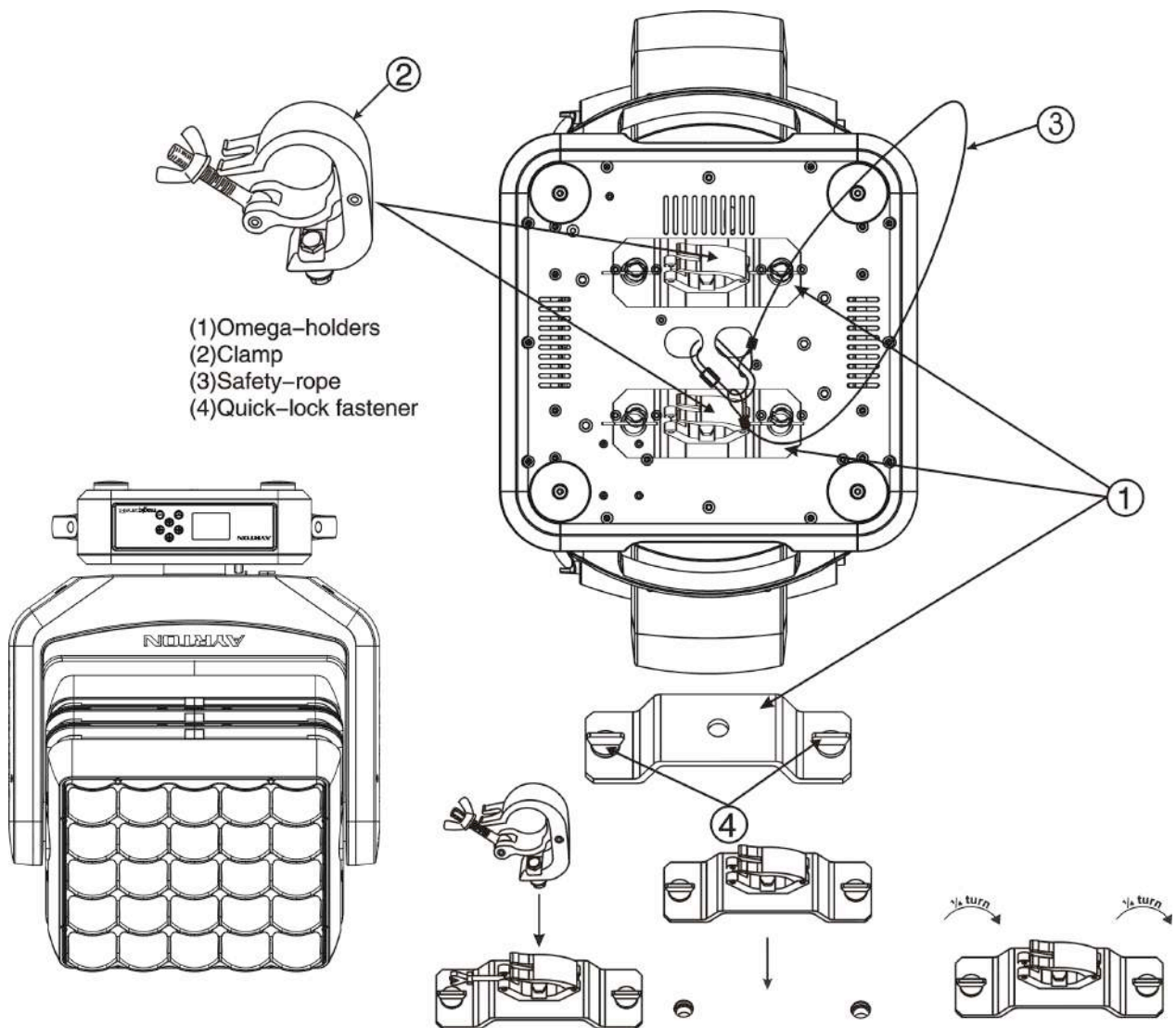

- Fixed the clamp on the bracket by tighten up the M12 screw on the bracket to the $\Phi 13$ hole in the middle of the bracket.
- Insert the quick-lock fasteners of the first Omega holder into the respective holes on the bottom of the device. Tighten the quick-lock fasteners fully clockwise.
- Install the second Omega holder.
- Pull the safety-rope through the holes on the bottom of the base and over the trussing system or a safe fixation spot. Insert the end in the carabine and tighten the safety screw.

Notice: this step is quite important to ensure that the fixture will not drop out by the damage of the clamp.

Dimensional Drawings:

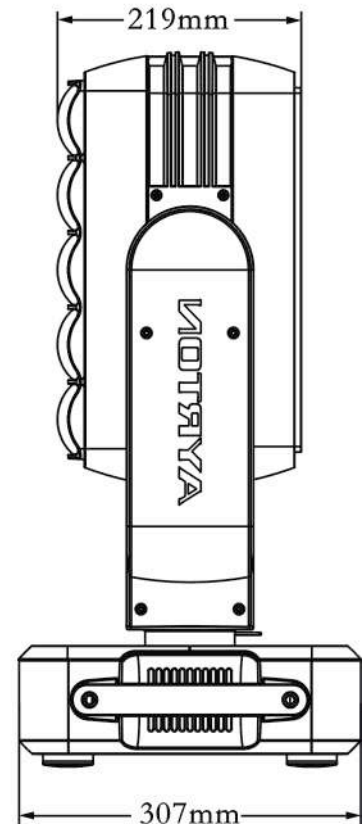
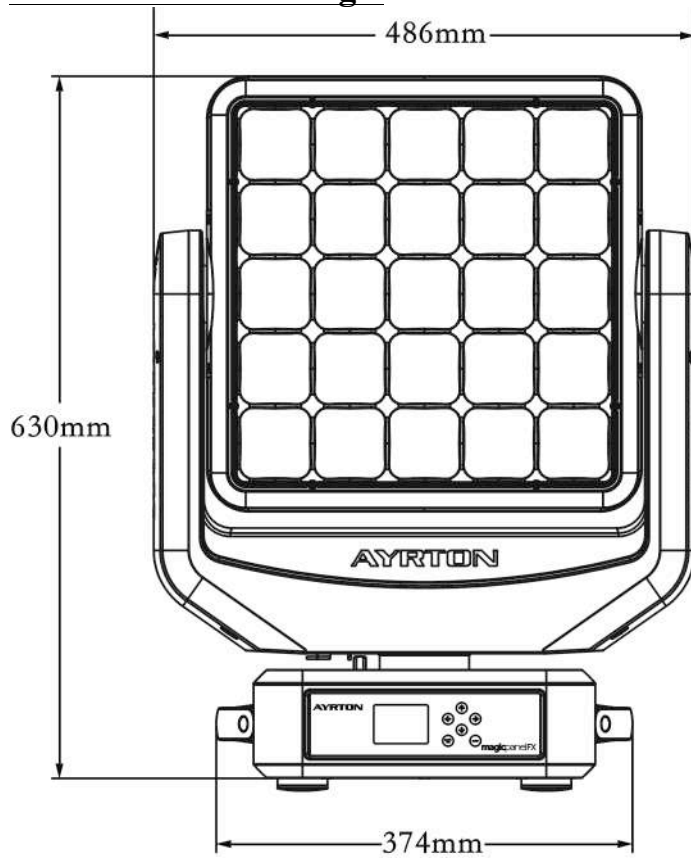

Layout Drawings:

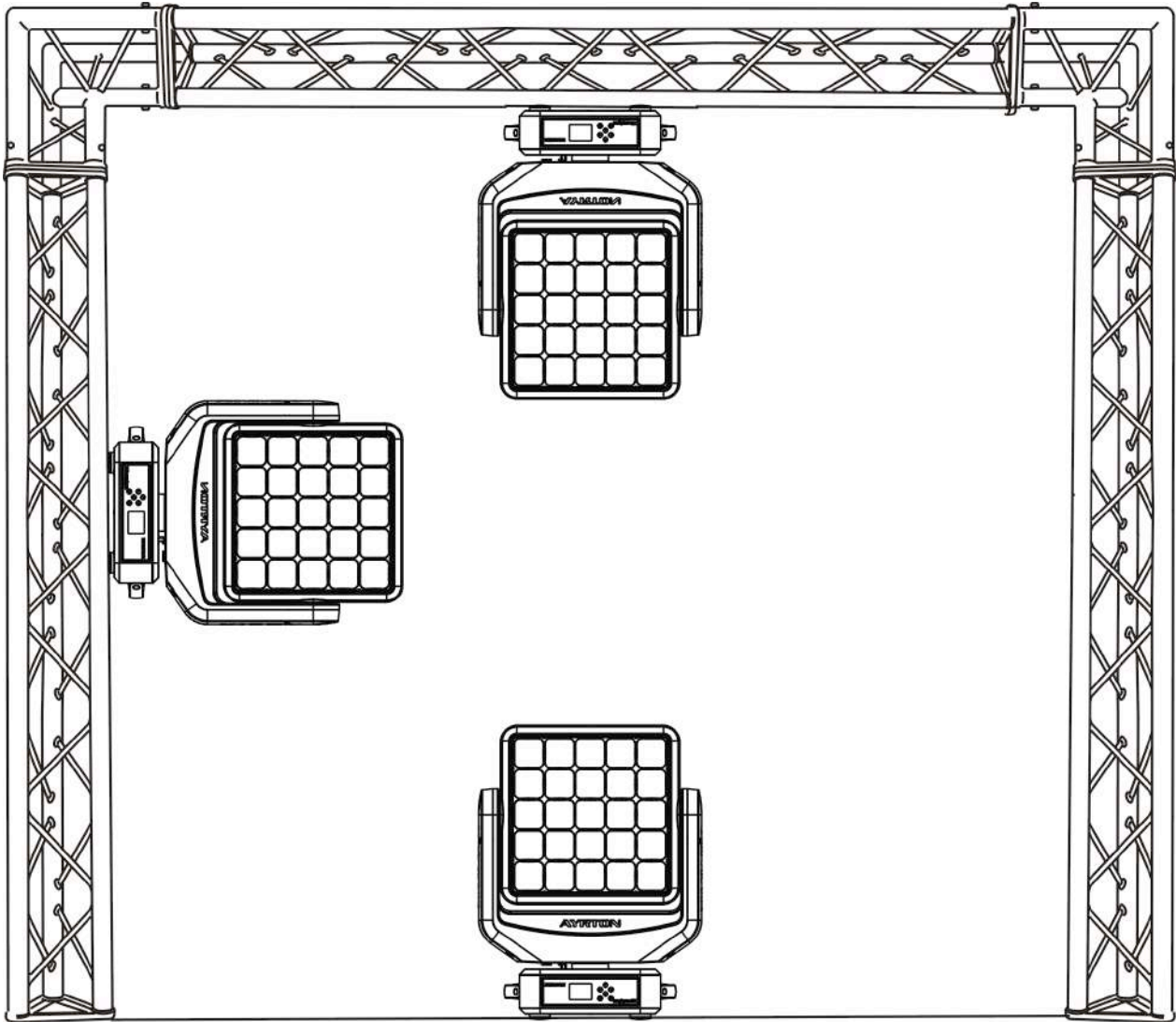

Mounting points

Be sure this fixture is kept at least 0.5m away from any flammable materials (decoration etc.). Always use and install the supplied safety cable as a safety measure to prevent accidental damage and/or injury in the event the clamp fails.

Overhead mounting requires extensive experience, including amongst others calculating working load limits, a fine knowledge of the installation material being used, and periodic safety inspection of all installation material and the fixture. If you lack these qualifications, do not attempt the installation yourself. Improper installation can result in bodily injury.

5. DMX-512 control connection

Connect the provided XLR cable to the female 5-pin XLR output of your controller and the other side to the male 5-pin XLR input of the moving head. You can chain multiple Moving head together through serial linking. The cable needed should be two core, screened cable with XLR input and output connectors. Please refer to the diagram below.

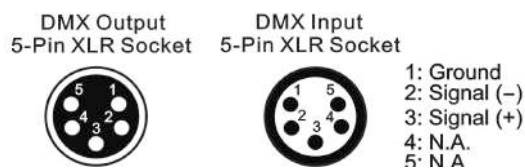

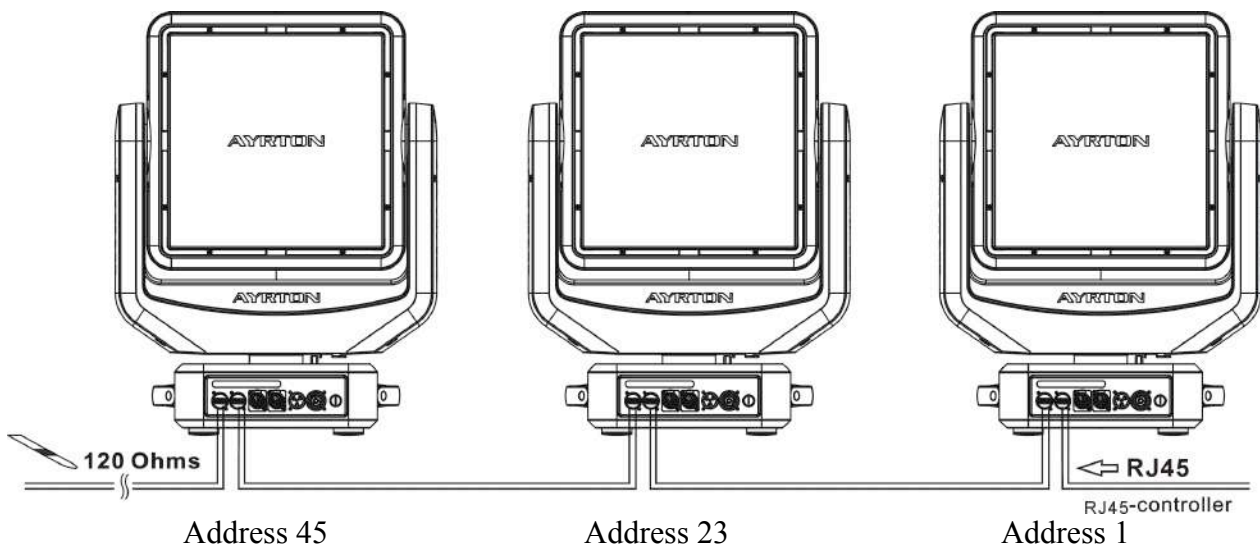

6. DMX-512 connection with DMX terminator

For installations where the DMX cable has to run a long distance or is in an electrically noisy environment, such as in a discotheque, it is recommended to use a DMX terminator. This helps in preventing corruption of the digital control signal by electrical noise. The DMX terminator is simply an XLR plug with a 120 Ω resistor connected between pins 2 and 3, which is then plugged into the output XLR socket of the last fixture in the chain. Please see illustrations below.

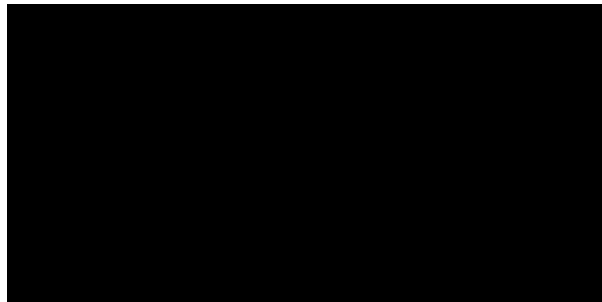

7. Projector DMX start address selection

All fixtures should be given a DMX starting address when using a DMX signal, so that the correct fixture responds to the correct control signals. This digital starting address is the channel number from which the fixture starts to “listen” to the digital control information sent out from the DMX controller. The allocation of this starting address is achieved by setting the correct number on the display located on the base of the device.

You can set the same starting address for all fixtures or a group of fixtures, or make different address for each fixture individually.

If you set the same address, all the units will start to “listen” to the same control signal from the same channel number. In other words, changing the settings of one channel will affect all the fixtures simultaneously.

If you set a different address, each unit will start to “listen” to the channel number you have set, based on the quantity of control channels of the unit. That means changing the settings of one channel will affect only the selected fixture.

In the case of the led move head, which is a 22 channel fixture, you should set the starting address of the first unit to 1, the second unit to 23 (22+ 1), the third unit to 45 (22+ 23), and so on.

8. Operating instructions of the internal DMX wireless system

1. Equipments:

DMX 512 controller, wireless transmitter, and the fixtures with wireless receiver.

2. Message from the LED indicator:

- 1) Rapid flashing red/Green: logging in to a transmitter
- 2) Slow flashing Red/Green: Logged on a transmitter and the DMX line is idle (No DMX is connected to transmitter).
- 3) Solid Green: Logged on to a transmitter and receiving DMX data.
- 4) Solid Red: Not logged on to a transmitter (free)

3. WDMX in the menu of the fixture:

On a fixture installed with wireless system, in order to switch between wireless control system and traditional DMX control (with cable), a new menu WDMX is added to the display board.

ON: (Activate WDMX)

1) When the fixture is on power, and the WDMX is activated to ON status, but did not connect to the controller and did not log in to the transmitter, the fixture will search for the DMX signal source. If the fixture is connected to the DMX controller it can be controlled by DMX controller; if it is log in to the wireless transmitter, it can be controlled by the Transmitter

2) When the fixture is power off, and the WDMX is in ON status, if the fixture is connected to DMX controller. After the fixture is power on, it can be controlled only by the DMX controller which connected. The fixture can log in the wireless transmitter, and receive only radio signal from transmitter, but not DMX from the transmitter.

OFF: (De-activate WDMX)

In this status, wireless system is not activated, so the fixture can not log in the transmitter.

REST: (reset WDMX memory);

Can remove the fixture from the connection with the transmitter, the fixture become free and ready to log in any transmitter.

4. Setup the wireless system:

- 1) Connect the transmitter with the DMX controller
- 2) To make the fixture installed with wireless receiver log in to the transmitter
 - a) Initially, the indicator on the receiver fixture should be in Solid red
 - b) Press and hold the configuration button on transmitter for less than 3 seconds the red/green LEDs on the transmitter and the receiver fixture will flash rapidly for about 5~ 10 seconds while the system goes through its setup procedure.
 - c) Once the receiver fixture is logged in to the transmitter (T1), the fixture with wireless receiver will keep the memory, even if restart the power, this unit will log in the transmitter (T1) automatically.
- 3) Use the DMX 512 to control the fixture

5. Remove the receivers from transmitter (T1) and to log in to another transmitter (T2)

Case 1: Remove a receiver:

- a) On the control board of the fixture, enter menu to activated the function of REST;
- b) The LED for wireless on the fixture should turn to Solid red; the receiver can log out from the transmitter (T1);
- c) press the configuration button on transmitter(T2) for less than 3 second, then the fixture will start to connect with the transmitter(T2)

Case 2: Remove all receivers from a transmitter (T1) to log in to T2;

- a) Press and hold the configuration button on the T1 as least 5 seconds, can clear the connection with all the fixtures.
- b) All the red/green LEDs on the receiver fixtures will turn to Solid red to indicate that the receivers are unassigned and removed from the transmitter (T1);
- c) Press and hold the configuration button on the T2 less then less than 3 second , the fixtures will connect with the T2

PS: 1. Please log the receivers out from the transmitter after every job, so that the receivers are in free un assigned state and ready to be assigned to a transmitter.

2. Do not connect the fixture which is under the communication of wireless system to the DMX controller, otherwise it will cause interference from the DMX controller.

9. Control Board

The Control Board offers several features: you can simply set the starting address , run the pre-programmed program or make a reset.

The main menu is accessed by pressing the  -button until the display starts flashing.

Browse through the menu by pressing the  -button ,  -button ,  -button or

 -button. Press the Enter-button in order to select the desired menu. You can change the

selection by pressing the the  -button ,  -button ,  -button or  -button.

Confirm every selection by pressing the  -button. You can leave every mode or access the

display menu via the internal battery by pressing the  -button for 5 minute; The functions provided are described in the following sections. it will exit from flash 10 seconds after the last keypress. Press this key under edit mode, . The functions provided are described in the following sections.

| Address | Set Dmx Addr | A001~AXXX | DMX address setting |
|------------|--------------|--|---------------------------------------|
| Users Mode | User Mode | Stand Mode Basic Mode Extend Mode User Mode A User Mode B User Mode C | User's mode to change channel numbers |
| | Edit User | Max channel PAN : | Preset User modes : |

| | | | | |
|---------|---------------|--|---|--|
| Options | Status | No DMX Mode Pan Reverse Tilt Reverse Pan Degree Tilt Degree Feedback Pan/Tilt Spd Hibernation | Close/Hold/Auto ON/OFF ON/OFF 630/540 270/540 ON/OFF Speed 1~ 4 OFF, 01M~99M, 15M | Auto run if no DMX Pan Reverse movement Tilt Reverse movement Pan Degree Select Tilt Degree Select Movement Feedback Reset Pan/Tilt Stand by Mode |
| | Service PIN | Service PIN RDM PID Set Ip | Password=XXX XXXXXX xxx.xxx.xxx.xxx | Service Password“=050” RDM PID Code Set IP |
| | Fans Control | Head Control | Auto Stage Studio | Head Fans Speed Mode Select |
| | Disp.Setting | Shutoff Time Flip Display Key Lock DispFlash | 02~60m 05m ON/OFF ON/OFF ON/OFF | Display shutoff time Reverse 180 degree Key Lock No Signal Rash |
| | Signal Select | DMX WDMX Art—Net sACN | | DMX Wireless DMX Art-Net sACN |
| | Set Universe | xx | | Art-Net Universe NO. |
| | Temp. C/F | Celsius Fahrenheit | | Temperature switch between □/□ |
| | Initial Pos. | PAN =XXX | | Initial effect position |
| | Wireless DMX | Activate WDMX Act&Data Out Rest WDMX | | Activate WDMX Act & Data Out Reset Wireless DMX Mem |
| | Trigger | DMX Value Disp. Set To Slave Auto Program | PAN..... Slave1,Slave2,S lave3 Master / Alone | DMX value display Slave setting Auto program |
| | ResetDefault | ON/OFF | Restore factory set. | |
| Info | Time Info. | Current Time Ttl Life Hrs Last Run Hrs Timer PIN Clr Last Run | | XXXX(Hours) XXXX(Hours) XXXX(Hours) Password=XXX ON/OFF |
| | Temp. Info | Head Temp. | | XXX□/□ |
| | Software Ver | Vx.x.x | | Software version |
| | Network | IP,Mask,Mac | | Network setting |
| Test | Home | All Pan&Tilt | | Reset all motors Reset Pan/Tilt |
| | Test Channel | PAN | | Test function |

| | | | | |
|--------|--------------|--|---|---|
| | Manual Ctrl. | PAN =XXX : | | Fine adjustment of the lamp |
| | Calibration | -Password- PAN : | | Password "050" Calbrate and adjust the effects to standard/right position |
| Preset | Select Prog. | Prog. Part 1 = Program 1 ~ 10 Program 1 Prog. Part 2 = Program 1 ~ 10 Program 2 Prog. Part 3 = Program 1 ~ 10 Program 3 | | Select programs to be run |
| | Edit Prog. | Program 1 : Program 10 | Program Test Step 01=SCxxx Step 64=SCxxx | Testing program Program in loop Save and exit |
| | Edit Scenes | Edit Scene 001 ~ Edit Scene 250 | Pan,Tilt,..... --Fade Time-- --Secne Time-- Input By Outside | Save and automatically return manual scenes edit |
| | Scenes Input | XX~XX | | Automat. scenes rec |

Default settings shaded

9.1 Address

9.1.1 Set Dmx Addr

With this function, you can adjust the desired DMX-address via the Control Board.

1. Access the main menu.
2. Tap the <Up/Down>button until "Set Dmx Addr" is displayed.
3. Press ENTER, the display will show "Set Dmx Addr" .
4. Tap the <Up/Down>button, the display will show "A001~AXXX"
5. Press ENTER to confirm or press <MODE/ESC> to return to the main menu.

9.2 Users mode

In this menu, user can select different channels list by different sequence:

For example, after the user enter this manual, if select Auto Program = CH 22, means in this User's mode, the "Dimmer" is in Channel 16.

9.2.1 User mode

With this function, you can create user defined channel orders.

9.2.2 Edit User

With this function, you can adjust the rest user defined channel order.

1. Access the main menu.
2. The display show "Edit User" frist channel, Press <Up/Down> the display will show "Edit User" .
3. Press <ENTER> to confirm or press <MODE/ESC> to return to the main menu.

9.3 Options

9.3.1 Status

No DMX Mode

With this function, when the drive is not DMX signal, it runs automatism, close, hold and music, the default is hold.

1. Access the main menu.
2. Press <Up/Down>, the display will show “No DMX Mode” .
3. Press< ENTER>, the display will show “No DMX Mode” .
4. The display show “Hold” ,Press <Up/Down>, the display will show “Close”, “Auto”.
5. Press <ENTER> to confirm or press <MODE/ESC> to return to the main menu.

Pan Reverse

With this function you can reverse the Pan-movement.

1. Access the main menu.
2. Press <Up/Down>, the display will show “Pan Reverse” .
3. Press< ENTER>, the display will show “Pan Reverse” .
4. The display show “OFF” ,Press <Up/Down>, the display will show “ON” .
5. Press <ENTER> to confirm or press <MODE/ESC> to return to the main menu.

Tilt Reverse

With this function you can reverse the Tilt-movement.

1. Access the main menu.
2. Press <Up/Down>, the display will show “Tilt Reverse” .
3. Press< ENTER>, the display will show “Tilt Reverse” .
4. The display show “OFF” ,Press <Up/Down>, the display will show “ON” .
5. Press <ENTER> to confirm or press <MODE/ESC> to return to the main menu.

Pan Degree

With this function, you can select pan degree for 630 or 540.

1. Access the main menu.
2. Press <Up/Down>, the display will show “Pan Degree” .
3. Press< ENTER>, the display will show “Pan Degree” .
4. The display show “540” ,Press <Up/Down>, the display will show “630” .
5. Press <ENTER> to confirm or press <MODE/ESC> to return to the main menu.

Feedback

With this function, you can feedback switch of pan movement or tilt movement.

1. Access the main menu.
2. Press <Up/Down>, the display will show “Feedback” .
3. Press< ENTER>, the display will show “Feedback” .
4. The display show “ON” ,Press <Up/Down>, the display will show “OFF” .
5. Press <ENTER> to confirm or press <MODE/ESC> to return to the main menu.

Pan/Tilt Spd

With this function, you can select scan mode from 1 to 4.

1. Access the main menu.
2. Press <Up/Down>, the display will show “Pan/Tilt Spd” .
3. Press< ENTER>, the display will show “Pan/Tilt Spd” .
4. The display show “Speed 1” ,Press <Up/Down>, the display will show “Speed 2”, “Speed 3”, “Speed 4”.
5. Press <ENTER> to confirm or press <MODE/ESC> to return to the main menu.

Hibernation ——Standby mode

The lamp and step motors will be power off if the fixture stay without DMX signal for 15 mins (Factory default).And the fixture will be reset before working once it receive DMX signal again.

1. Access the main menu.
2. Press <Up/Down>, the display will show “Hibernation” .
3. Press< ENTER>, the display will show “Hibernation” .
4. The display show “15M” ,Press <Up/Down>, the display will show “01M”, “02M” “99M” or “OFF” .
5. Press <ENTER> to confirm or press <MODE/ESC> to return to the main menu.

9.3.2 Service PIN

Service PIN——The Password for this function is “50”.

RDM PID—— With this function you can call up various submenus via RDM.

This device is RDM ready. RDM stands for "remote device management" and makes remote control of devices connected to the DMX-bus. ANSI E1.20-2006 by ESTA specifies the RDM standard as an extension of the DMX512 protocol.

Manual settings like adjusting the DMX starting address are no longer needed. This is especially useful when the device is installed in a remote area.

RDM ready and conventional DMX devices can be operated in one DMX line. The RDM protocol sends own packages in the DMX512 data feed and does not influence conventional devices.

Set IP

1. Access the main menu.
2. Press <Up/Down>, the display will show “Set IP.” .
3. Press< ENTER>, the display will show “Set IP” .
4. The display show “xxx.xxx.xxx.xxx” .
5. Press <ENTER> to confirm or press <MODE/ESC> to return to the main menu.

9.3.3 Fans Control

With this function, you can set the speed of the running fans. The selections have Auto、Stage and Studio.

1. Access the main menu.
2. The display show “Auto” , Press <Up/Down>, the display will show “Stage”, “Studio”.
3. Press <ENTER> to confirm or press <MODE/ESC> to return to the main menu.

9.3.4 Disp.Setting

Shutoff Time

With this function you can shut off the color LCD display after 2 to 60 minutes. Turn the encoder in order to select the desired shut off time. The default is 5 minute.

Flip Display

With this function you can the entire display to be flipped by 180° to allow for better view when the fixture is hung from truss or a ceiling. This function is disabled as default.

1. Access the main menu.
2. Press <Up/Down>, the display will show “Flip Display” .
3. Press< ENTER>, the display will show “Flip Display” .

4. The display show “OFF” ,Press <Up/Down>, the display will show “ON” .
5. Press <ENTER> to confirm or press <MODE/ESC> to return to the main menu.

Key Lock

With this function you can activate the automatic keylock status. If this function is activated, the keys will be locked automatically after exiting the edit mode for 15 seconds. keeping press the [MENU] key for 3seconds if you do not need this function.

1. Access the main menu.
2. Press <Up/Down>, the display will show “Key Lock” .
3. Press< ENTER>, the display will show “Key Lock” .
4. The display show “OFF” ,Press <Up/Down>, the display will show “ON” .
5. Press <ENTER> to confirm or press <MODE/ESC> to return to the main menu.

DispFlash

With this function you can the entire display to be flipped by 180° to allow for better view when the fixture is hung from truss or a ceiling. This function is disabled as default.

1. Access the main menu.
2. Press <Up/Down>, the display will show “DispFlash” .
3. Press< ENTER>, the display will show “DispFlash” .
4. The display show “OFF” ,Press <Up/Down>, the display will show “ON” .
5. Press <ENTER> to confirm or press <MODE/ESC> to return to the main menu.

9.3.5 Signal Select

1. Access the main menu.
2. Press <Up/Down>, the display will show “Signal Select” .
3. Press< ENTER>, the display will show “Signal Select” .
4. The display show “DMX” ,Press <Up/Down>, the display will show “WDMX” , “Art--Net” , “sACN” .
5. Press <ENTER> to confirm or press <MODE/ESC> to return to the main menu.

9.3.6 Set Universe

1. Access the main menu.
2. Press <Up/Down>, the display will show “Set Universe” .
3. Press< ENTER>, the display will show “Set Universe” .
4. The display show “xx” .
5. Press <ENTER> to confirm or press <MODE/ESC> to return to the main menu.

9.3.7 Temp. C/F

With this function, Display the temperature for Celsius or Fahrenheit.

1. Access the main menu.
2. Press <Up/Down>, the display will show “Temp. C/F” .
3. Press< ENTER>, the display will show “Temp. C/F” .
4. The display show “Celsius” ,Press <Up/Down>, the display will show “Fahrenheit”.
5. Press <ENTER> to confirm or press <MODE/ESC> to return to the main menu.

9.3.8 Initial Pos.

With this function, Display initial effect position.

1. Access the main menu.

2. Press <Up/Down>, the display will show “Initial Pos.” .
3. Press< ENTER>, the display will show “Initial Pos.” .
4. The display show “PAN=XXX” .
5. Press <ENTER> to confirm or press <MODE/ESC> to return to the main menu.

9.3.9 Wireless DMX

From factory, this projector is prepared for wireless data transmission (W-DMX). If you wish to de-activate W-DMX control, you can select the function “De-activate WDMX” by turning the encoder. With the function “rest”, you can log out the projector from the wireless sender.

1. Access the main menu.
2. Press <Up/Down>, the display will show “Wireless DMX” .
3. Press< ENTER>, the display will show “Wireless DMX” .
4. The display show “Activate WDMX” , Press <Up/Down>, the display will show “Act&Data Out” ,“Rest WDMX”.
5. Press <ENTER> to confirm or press <MODE/ESC> to return to the main menu.

9.3.10 Trigger

DMX Value Disp.

With this function you can display the DMX 512 value of each channel. The display automatically shows the channel with a value changing.

1. Access the main menu.
2. Tap the <Up/Down>button until “DMX Value Disp.” is displayed.
3. Press ENTER, the display will show “DMX Value Disp.” .
4. Tap the <Up/Down>button, choose each channel.
5. Press ENTER to confirm or press <MODE/ESC> to return to the main menu.

Set To Slave

With this function, you can define the device as slave.

1. Access the main menu.
2. Tap the <Up/Down>button until “Set To Slave” is displayed.
3. Press ENTER, the display will show “Set To Slave” .
4. Tap the <Up/Down>button, the display will show “Slave1”, ”Slave2”, ”Slave3”.
5. Press ENTER to confirm or press <MODE/ESC> to return to the main menu.

Auto Program

With this function, you can run the internal program. You can select the desired program under “**Select program**”. You can set the number of steps under “**Edit program**”. You can edit the individual scenes under “**Edit scenes**”. With this function, you can run the individual scenes either automatically, i.e. with the adjusted Step-Time.

1. Access the main menu.
2. Tap the <Up/Down>button until “Auto Program” is displayed.
3. Press ENTER, the display will show “Auto Program” .
4. Tap the <Up/Down>button, the display will show “Master”, ”Alone”.
5. Press ENTER to confirm or press <MODE/ESC> to return to the main menu.

9.3.11 ResetDefault

With this function, you can select restore factory set for ON or OFF, the default is OFF.

1. Access the main menu.
2. Press <Up/Down>, the display will show “ResetDefault” .

3. Press< ENTER>, the display will show “ResetDefault” .
4. The display show “OFF” ,Press <Up/Down>, the display will show “ON”.
5. Press <ENTER> to confirm or press <MODE/ESC> to return to the main menu.

9.4 Info

9.4.1 Time info.

Current Time

With this function, you can display the temporary running time of the device from the last power on. The display shows “XXXX”, “XXXX” stands for the number of hours. The counter is resetted after turning the device off.

1. Access the main menu.
2. the display will show “Time Information” .
3. Press <Up/Down>, the display will show “Current Time” .
4. Press< ENTER>, the display will show “Current Time” .
5. The display will show “XXXX” (Hours) ;
6. Press <ENTER> to confirm or press <MODE/ESC> to return to the main menu.

Ttl Life Hrs

With this function, you can display the running time of the device. The display shows “XXXX”, “XXXX” stands for the number of hours.

1. Access the main menu.
2. Press <Up/Down>, the display will show “Ttl Life Hrs” .
3. Press< ENTER>, the display will show “Ttl Life Hrs” .
4. The display will show “XXXX” (Hours) ;
5. Press <ENTER> to confirm or press <MODE/ESC> to return to the main menu.

Last Run Hrs

With this function, you can display last the running time of the lamp. The display shows “XXXX”, “XXXX” stands for the number of hours

1. Access the main menu.
2. Press <Up/Down>, the display will show “Last Run Hrs” .
3. Press< ENTER>, the display will show “Last Run Hrs” .
4. The display will show “XXXX” (Hours) ;
5. Press <ENTER> to confirm or press <MODE/ESC> to return to the main menu.

Timer PIN

With this function, you can display the timer password.

1. Access the main menu.
2. Press <Up/Down>, the display will show “Timer PIN” .
3. Press< ENTER>, the display will show “Timer PIN” . The time password is 038.
4. Press <ENTER> to confirm or press <MODE/ESC> to return to the main menu.

Clr Last Run

With this function, you can clear last run time of the fixture. The display shows “ON” or “OFF”, Press “Enter” to confirm.

1. Access the main menu.
2. Press <Up/Down>, the display will show “Clr Last Run” .
3. At “Timer PIN” menu input right password, Press< ENTER>, the display will show “Clr Last Run” .

4. The display show “OFF” ,Press <Up/Down>, the display will show “ON” .
5. Press <ENTER> to confirm or press <MODE/ESC> to return to the main menu.

9.4.2 Temp. Info

Head Temp.

With this function you can display the temperature on the display board of the base (near CMY-filter) in Celsius.

1. Access the main menu.
2. Press <Up/Down>, the display will show “Head Temp.” .
3. Press< ENTER>, the display will show “Head Temp.” .
4. The display show “XXX ° C/ ° F”.
5. Press <ENTER> to confirm or press <MODE/ESC> to return to the main menu.

9.4.3 Software ver

With this function, you can display the software version of the device.

1. Access the main menu.
2. Press <Up/Down>, the display will show “Software ver” .
3. Press< ENTER>, the display will show “Software ver” .
4. The display show “Ver x.x”.
5. Press <ENTER> to confirm or press <MODE/ESC> to return to the main menu.

9.4.4 Network

1. Access the main menu.
2. Press <Up/Down>, the display will show “Network” .
3. At “Timer PIN” menu input right password, Press< ENTER>, the display will show “Network” .
4. The display show “IP”, Press <Up/Down>, the display will show “Mask”, “Mac”.
5. Press <ENTER> to confirm or press <MODE/ESC> to return to the main menu.

9.5 Test

9.5.1 Home

With this function you can reset the device via the Control Board. You can select the different reset functions by turning the encoder.

1. Access the main menu.
2. The display show “All” , Press <Up/Down>, the display will show “All”, “Pan&Tilt” , “Other” .
3. Press <ENTER> to confirm or press <MODE/ESC> to return to the main menu.

9.5.2 Test Channel

With this function you can test each channel on its (correct) function.

1. Access the main menu.
2. Press <Up/Down>, the display will show “Test Channel” .
3. Press< ENTER>, the display will show “Test Channel” .
4. The display show “Pan Moving” frist channel, Press <Up/Down>, can choose other channel.
5. Press <ENTER> to confirm or press <MODE/ESC> to return to the main menu.

9.5.3 Manual Ctrl.

With this function, you can adjust the lamp more easily. All effects will be canceled, the shutter opens and the dimmer intensity will be set to 100 %. With the individual functions, you can

focus the light on a flat surface (wall) and perform the fine lamp adjustment.

1. Access the main menu.
2. Press <Up/Down>, the display will show “Manual Ctrl.” .
3. Press< ENTER>, the display will show “Manual Ctrl.” .
4. The display show “PAN=XXX” .
5. Press <ENTER> to confirm or press <MODE/ESC> to return to the main menu.

9.5.4 Calibration

With this function, you can calibrate and adjust the effect wheels to their correct positions. The password of calibrate values is 050.

1. Access the main menu.
2. Press <Up/Down>, the display will show “Calibration” .
3. Press< ENTER>, the display will show “Calibration” .
4. The display show “Password=XXXX” .
5. Press <ENTER> to confirm or press <MODE/ESC> to return to the main menu.

9.6 Preset

9.6.1 Select Prog.

With this function, you can select the program for the Program Run.

9.6.2 Edit Prog.

With this function, you can edit the internal programs.

9.6.3 Edit Scenes

With this function, you can edit the scenes of the internal programs.

9.6.4 Scenes Input

The moving head features an integrated DMX-recorder by which you can transmit the programmed scenes from your DMX-controller to the moving head. Adjust the desired scene numbers via the encoder (from – to). When you call up the scenes at your controller, they will automatically be transmitted to the moving head.

Excursion:

A Master unit can send up to 3 different data groups to the Slave units, i.e. a Master unit can start 3 different Slave units, which run 3 different programs. The Master unit sends the 3 program parts in a continuous loop.



The Slave unit receives data from the Master unit according to the group which the Slave unit was assigned to. If e.g. a Slave unit is set to “Slave 1” in the menu “Set to Slave”, the Master unit sends “Auto Program Part 1” to the Slave unit. If set to “Slave 2”, the Slave unit receives “Auto Program Part 2”.

To start a Auto Program please proceed as follows:

1. Slave-Setting

- Select “Function Mode” by turning the encoder.
- Press the Enter button to confirm.
- Select “Set to slave” by turning the encoder.
- Press the Enter button to confirm.

- Turn the encoder to select “Slave 1”, “Slave 2” or “Slave 3”.
- Press the Enter button to confirm.
- Press the MODE/ESC button in order to return to the main menu.

2. Automatic Program Run

- Select “Function Mode” by turning the encoder.
- Press the Enter button to confirm.
- Select “Auto Program” by turning the encoder.
- Press the Enter button to confirm.
- Turn the encoder to select “Master” or “Alone”. The selection "Alone" means Stand Alone-mode and "Master" that the device is defined as master.
- Press the Enter button to confirm.
- Press the MODE/ESC button in order to return to the main menu.

3. Program selection for Auto Pro Part

- Select “Edit program” by turning the encoder.
- Press the Enter button to confirm.
- Select “Select programs” by turning the encoder.
- Press the Enter button to confirm.
- Turn the encoder to select “Auto Pro Part 1”, “Auto Pro Part 2” or “Auto Pro Part 3”, and thus select which Slave program is to be sent. Selection “Part 1” means, that the Slave unit runs the same program as the master units.
- Press the Enter button to confirm.
- Press the MODE/ESC button in order to return to the main menu.

4. Program selection for Edit Program

- Select “Edit program” by turning the encoder.
- Press the Enter button to confirm.
- Select “Edit program” by turning the encoder.
- Press the Enter button to confirm.
- Turn the encoder to select the desired program. With this function you can edit specific scenes into a specific program.
- Press the Enter button to confirm.
- Press the MODE/ESC button in order to return to the main menu.

5. Automatic Scene Recording

- Select “Edit program” by turning the encoder.
- Press the Enter button to confirm.
- Select “Edit scenes” by turning the encoder.
- Turn the encoder to select the desired scene numbers. You can program a maximum number of 250
- Press the Enter button to confirm.
- Press the MODE/ESC button in order to return to the main menu.

Example:

Program 2 includes scenes: 10, 11, 12, 13

Program 4 includes scenes: 8, 9, 10

Program 6 includes scenes: 12, 13, 14, 15

Auto Pro Part 1 is Program 2;

Auto Pro Part 2 is Program 3;

Auto Pro Part 3 is Program 6

The 3 Slave groups run the Auto Program in certain time segments, as shown in the following

picture:

Part 1:

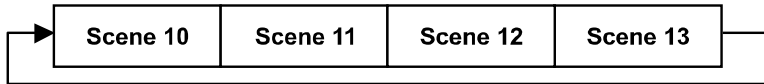

Part 2:

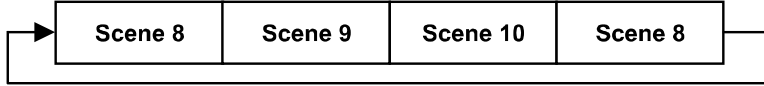

Part 3:

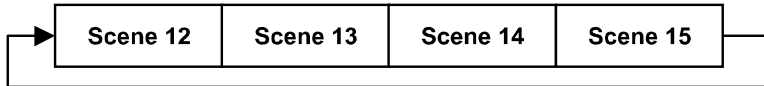

10. INSTRUCTIONS ON USE:

| DMX channel's functions and their values (118 DMX channels): | | | | |
|--|----|----|---------|--|
| Mode/Channel | | | Value | Function |
| St | Ba | Ex | | |
| 1 | 1 | 1 | | PAN Movement 8bit : |
| | | | 0-255 | Pan Movement |
| 2 | | 2 | | Pan Fine 16bit |
| | | | 0-255 | Fine control of Pan movement |
| 3 | 2 | 3 | | TILT Movement 8bit : |
| | | | 0-255 | Tilt Movement |
| 4 | | 4 | | Tilt Fine 16bit |
| | | | 0-255 | Fine control of Tilt movement |
| 5 | 3 | 5 | | Speed Pan/Tilt movement: |
| | | | 0-225 | max to min speed |
| | | | 226-235 | blackout by movement |
| 6 | 4 | 6 | | Pan Motor continuous rotation |
| | | | 0-127 | no function |
| | | | 128-189 | Forwards Pan rotation from fast to slow |
| | | | 190-193 | No rotation |
| 7 | 5 | 7 | | Tilt Motor continuous rotation |
| | | | 0-127 | no function |
| | | | 128-189 | Forwards Tilt rotation from fast to slow |

| | | | |
|----|---|-------------|---|
| | | 190-193 | No rotation |
| | | 194-255 | Backwards Tilt rotation from slow to fast |
| 8 | 6 | | Red LED -all arrays : |
| | | 0-255 | Red (0-Black , 255-100% Red) |
| 9 | 7 | | Green LED-all arrays : |
| | | 0-255 | Green (0-Black , 255-100% Green) |
| 10 | 8 | | Blue LED -all arrays : |
| | | 0-255 | Blue (0-Black , 255-100% Blue) |
| 11 | 9 | | White LED -all arrays : |
| | | 0-255 | White (0-Black , 255-100% White) |
| | | 19 | Red LED -array 1 : |
| | | 0-255 | Red (0-Black , 255-100% Red) |
| | | 20 | Green LED-array 1 : |
| | | 0-255 | Green (0-Black , 255-100% Green) |
| | | 21 | Blue LED -array 1 : |
| | | 0-255 | Blue (0-Black , 255-100% Blue) |
| | | 22 | White LED -array 1 : |
| | | 0-255 | White (0-Black , 255-100% White) |
| | | 23 | Red LED -array 2 : |
| | | 0-255 | Red (0-Black , 255-100% Red) |
| | | 24 | Green LED-array 2 : |
| | | 0-255 | Green (0-Black , 255-100% Green) |
| | | 25 | Blue LED -array 2 : |
| | | 0-255 | Blue (0-Black , 255-100% Blue) |
| | | 26 | White LED -array 2 : |
| | | 0-255 | White (0-Black , 255-100% White) |
| | | o o o o o o | — |
| | | 115 | Red LED -array 25 : |
| | | 0-255 | Red (0-Black , 255-100% Red) |
| | | 116 | Green LED-array 25 : |
| | | 0-255 | Green (0-Black , 255-100% Green) |
| | | 117 | Blue LED -array 25 : |
| | | 0-255 | Blue (0-Black , 255-100% Blue) |
| | | 118 | White LED -array 25 : |
| | | 0-255 | White (0-Black , 255-100% White) |

| | | | | |
|---------|-------------|----|---------|---------------------------------------|
| 12 | 10 | 8 | | <u>Shutter, strobe:</u> |
| | | | 0-31 | Led trun off |
| | | | 32-63 | Led turn on |
| | | | 64-95 | Strobe effect slow to fast |
| | | | 96-127 | Led turn on |
| | | | 128-159 | Pulse-effect in sequences |
| | | | 160-191 | Led turn on |
| | | | 192-223 | Random strobe effect slow to fast |
| 224-255 | Led turn on | | | |
| 13 | 11 | 9 | | <u>Dimmer intensity:</u> |
| | | | 0-255 | Intensity 0 to 100% |
| 14 | 12 | 10 | | <u>Color Macro:</u> |
| | | | 0-7 | No function |
| | | | 8-39 | from RED to YELLOW |
| | | | 40-71 | from YELLOW to GREEN |
| | | | 72-103 | from GREEN to CYAN |
| | | | 104-135 | from CYAN to BLUE |
| | | | 136-167 | from BLUE to MAGENTA |
| | | | 168-199 | from MAGENTA to RED |
| | | | 200-231 | from RED to WHITE |
| | | | 232-255 | Crossfading colours from slow to fast |
| 15 | 13 | 11 | | <u>Color Presets:</u> |
| | | | 0-4 | No function |
| | | | 5--9 | White2700k |
| | | | 10--14 | White3200k |
| | | | 15-19 | White4200k |
| | | | 20-24 | White5600k |
| | | | 25-29 | White6500k |
| | | | 30-34 | White8000k |
| | | | 35-39 | Yellow |
| | | | 40-44 | Magenta |
| | | | 45-49 | Cyan |
| | | | 50-54 | Salmon |
| | | | 55-59 | Turquoise |
| 60-64 | Light Green | | | |

| | | | | |
|----|----|----|---------|-------------------------------------|
| | | | 65-69 | Steel Blue |
| | | | 70-74 | Orange |
| | | | 75-79 | Straw |
| | | | 80-84 | Pale Lavander |
| | | | 85-89 | Pink |
| | | | 90-94 | Red |
| | | | 95-99 | Green |
| | | | 100-104 | Blue |
| | | | 105-109 | White |
| | | | 110-104 | Rainbow1 |
| | | | 115-119 | Rainbow2 |
| | | | 120-124 | Rainbow3 |
| | | | 125-255 | Reserved |
| 16 | 14 | 12 | | <u>Color Presets Dimmer:</u> |
| | | | 0-255 | Dimmer 0% to 100% |
| 17 | 15 | 13 | | <u>Chase Patterns:</u> |
| | | | 0--9 | Led trun off |
| | | | 10-11 | Chase 1 |
| | | | 12-13 | Chase 2 |
| | | | 14-15 | Chase 3 |
| | | | 16-17 | Chase 4 |
| | | | 18-19 | Chase 5 |
| | | | 20-21 | Chase 6 |
| | | | 22-23 | Chase 7 |
| | | | 24-25 | Chase 8 |
| | | | 26-27 | Chase 9 |
| | | | 28-29 | Chase 10 |
| | | | 30-31 | Chase 11 |
| | | | 32-33 | Chase 12 |
| | | | 34-35 | Chase 13 |
| | | | 36-37 | Chase 14 |
| | | | 38-39 | Chase 15 |
| | | | 40-41 | Chase 16 |
| | | | 42-43 | Chase 17 |
| | | | 44-45 | Chase 18 |

| | |
|---------|----------|
| 46-47 | Chase 19 |
| 48-49 | Chase 20 |
| 50-51 | Chase 21 |
| 52-53 | Chase 22 |
| 54-55 | Chase 23 |
| 56-57 | Chase 24 |
| 58-59 | Chase 25 |
| 60-61 | Chase 26 |
| 62-63 | Chase 27 |
| 64-65 | Chase 28 |
| 66-67 | Chase 29 |
| 68-69 | Chase 30 |
| 70-71 | Chase 31 |
| 72-73 | Chase 32 |
| 74-75 | Chase 33 |
| 76-77 | Chase 34 |
| 78-79 | Chase 35 |
| 80-81 | Chase 36 |
| 82-83 | Chase 37 |
| 84-85 | Chase 38 |
| 86-87 | Chase 39 |
| 88-89 | Chase 40 |
| 90-91 | Chase 41 |
| 92-93 | Chase 42 |
| 94-95 | Chase 43 |
| 96-97 | Chase 44 |
| 98-99 | Chase 45 |
| 100-101 | Chase 46 |
| 102-103 | Chase 47 |
| 104-105 | Chase 48 |
| 106-107 | Chase 49 |
| 108-109 | Chase 50 |
| 110-111 | Chase 51 |
| 112-113 | Chase 52 |
| 114-115 | Chase 53 |

| | |
|---------|----------|
| 116-117 | Chase 54 |
| 118-119 | Chase 55 |
| 120-121 | Chase 56 |
| 122-123 | Chase 57 |
| 124-125 | Chase 58 |
| 126-127 | Chase 59 |
| 128-129 | Chase 60 |
| 130-131 | Chase 61 |
| 132-133 | Chase 62 |
| 134-135 | Chase 63 |
| 136-137 | Chase 64 |
| 138-139 | Chase 65 |
| 140-141 | Chase 66 |
| 142-143 | Chase 67 |
| 144-145 | Chase 68 |
| 146-147 | Chase 69 |
| 148-149 | Chase 70 |
| 150-151 | Chase 71 |
| 152-153 | Chase 72 |
| 154-155 | Chase 73 |
| 156-157 | Chase 74 |
| 158-159 | Chase 75 |
| 160-161 | Chase 76 |
| 162-163 | Chase 77 |
| 164-165 | Chase 78 |
| 166-167 | Chase 79 |
| 168-169 | Chase 80 |
| 170-171 | Chase 81 |
| 172-173 | Chase 82 |
| 174-175 | Chase 83 |
| 176-177 | Chase 84 |
| 178-179 | Chase 85 |
| 180-181 | Chase 86 |
| 182-183 | Chase 87 |
| 184-185 | Chase 88 |

| | | | | |
|----|----|----|---------|------------------------------|
| | | | 186-187 | Chase 89 |
| | | | 188-189 | Chase 90 |
| | | | 190-191 | Chase 91 |
| | | | 192-193 | Chase 92 |
| | | | 194-195 | Chase 93 |
| | | | 196-197 | Chase 94 |
| | | | 198-199 | Chase 95 |
| | | | 200-201 | Chase 96 |
| | | | 202-203 | Chase 97 |
| | | | 204-205 | Chase 98 |
| | | | 206-207 | Chase 99 |
| | | | 208-209 | Chase 100 |
| | | | 210-211 | Chase 101 |
| | | | 212-213 | Chase 102 |
| | | | 214-215 | Chase 103 |
| | | | 216-217 | Chase 104 |
| | | | 218-219 | Chase 105 |
| | | | 220-221 | Chase 106 |
| | | | 222-223 | Chase 107 |
| | | | 224-225 | Chase 108 |
| | | | 226-227 | Chase 109 |
| | | | 228-229 | Chase 110 |
| | | | 230-231 | Chase 111 |
| | | | 232-233 | Chase 112 |
| | | | 234-235 | Chase 113 |
| | | | 236-235 | Reserved |
| 18 | 16 | 14 | | Chase Speed: |
| | | | 0-125 | Fast to Slow Backward |
| | | | 126-130 | Stop(Speed=0) |
| | | | 131-255 | Slow to Fast Forward |
| 19 | 17 | 15 | | Chase Fade: |
| | | | 0-255 | Fade Chase |
| 20 | 18 | 16 | | Zoom : |
| | | | 0-255 | Zoom adjustment from 60 to15 |
| 21 | | 17 | | Zoom Fine : |

| | | | | |
|----|----|----|---------|---|
| | | | 0-255 | Fine control for Zoom adjustment |
| 22 | 19 | 18 | | Reset, internal programs: |
| | | | 0-79 | Normal |
| | | | 80-84 | All motor reset |
| | | | 85-87 | Scan motor reset |
| | | | 88-90 | no function |
| | | | 91-93 | no function |
| | | | 94-96 | no function |
| | | | 97-99 | Others motor reset |
| | | | 100-119 | Internal program 1 (secne1~8 of EEPROM) |
| | | | 120-139 | Internal program 2 (secne9~16 of EEPROM) |
| | | | 140-159 | Internal program 3 (secne17~24 of EEPROM) |
| | | | 160-179 | Internal program 4 (secne25~32 of EEPROM) |
| | | | 180-199 | Internal program 5 (secne33~40 of EEPROM) |
| | | | 200-219 | Internal program 6 (secne41~48 of EEPROM) |
| | | | 220-239 | Internal program 7 (secne49~56 of EEPROM) |
| | | | 240-255 | Reserved |

11. ERROR MESSAGE

When you turn on the fixture, it will make a reset at first. The display may show “Err channel is XX” while there are problems with one or more channels. “XX” stands for channel 1, 2, 3, 4, 5, 6 who has the testing sensor for positioning. For example, when the display shows “Err channel is Red LED -all arrays”, it means there is some error in channel 1. If there are some errors on channel 1, channel 3 at the same time, you may see the error message, “Err channel is Pan movement”, “Err channel is Tilt movement”, flash repeated for 2 times, and then the fixture will generate a second reset. If the fixture remain error message after performing reset more than 2 times, only the channels which have errors can not work properly, others can work as usual. Please contact with dealer or manufacturer for service, self repair is not allowed.

PAN- movement Er

(PAN-yoke movement error) This message will appear after the reset of the fixture if the yoke’s magnetic-indexing circuit malfunction (sensor failed or magnet missing) or the stepping-motor is defective (or its driving IC on the main PCB). The PAN- movement is not located in the default position after the reset.

TILT- movement Er

(TILT-head movement error) This message will appear after the reset of the fixture if the head’s magnetic-indexing circuit malfunctions (sensor failed or magnet missing) or the stepping-motor is defective (or its driving IC on the main PCB). The TILT- movement is not located in the default position after the reset.

12. CLEANING AND MAINTENANCE

The following points have to be considered during the inspection:

- 1) All screws for installing the devices or parts of the device have to be tightly connected and must not be corroded.
 - 2) There must not be any deformations on the housing, color lenses, fixations and installation spots (ceiling, suspension, trussing).
 - 3) Mechanically moved parts must not show any traces of wearing and must not rotate with unbalances.
 - 4) The electric power supply cables must not show any damage, material fatigue or sediments.
- Further instructions depending on the installation spot and usage have to be adhered by a skilled installer and any safety problems have to be removed.



CAUTION!

Disconnect from mains before starting maintenance operation.

In order to make the lights in good condition and extend the life time, we suggest a regular cleaning to the lights.

- 1) Clean the inside and outside lens each week to avoid the weakness of the lights due to accumulation of dust.
- 2) Clean the fan each week.
- 3) A detailed electric check by approved electrical engineer each three month, make sure that the circuit contacts are in good condition, prevent the poor contact of circuit from overheating.

We recommend a frequent cleaning of the device. Please use a moist, lint- free cloth. Never use alcohol or solvents.

There are no serviceable parts inside the device except for the lamp. Please refer to the instructions under “Installation instructions”.

Should you need any spare parts, please order genuine parts from your local dealer.

13. TECHNICAL SPECIFICATIONS

Power supply: AC 100-240V~, 50/60Hz

Power consumption: 1000W

Packing dimensions: 73.5x58x42.5 cm

Net weight: ?KGS

Gross weight: ? KGS

Remark: errors and omissions for every information given in this manual excepted. All information is subject to change without prior notice.